

TM3400/TM3410

Thermostatic mixing valve
with scald protection

Product specification sheet

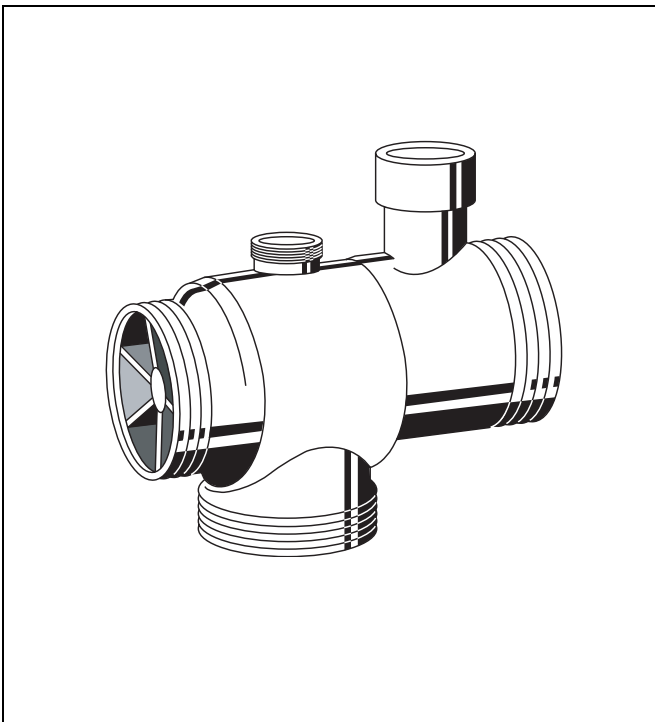

Construction

The thermostatic mixing valve comprises:

- Housing
- Cut-off switch
- Thermostat

Materials

- Red bronze housing
- Stainless steel cut-off switch

Application

Standard thermostatic mixing valves TM3400/TM3410 are used in domestic hot water central heating systems with or without recirculation. The aim is to maintain a constant temperature of the mixed water for users, by varying the temperature of the hot water stored. Thermostatic mixing valves also have applications in underfloor heating applications and in alternative energy systems, such as solar and woodchip systems.

Special Features

- Wide flow
- Lightness
- High degree of adjustment precision
- Scald protection
- Works without external energy
- Direct connection to recirculation circuit (except 1/2")
- Complete with female inlet couplings
- Reliable and proven

Range of Application

Medium Water

Technical Data

Hot water inlet temperature	Max. 90 °C
Operating pressure	Max. 10 bar
Setting ranges	20...30 °C Set during manufacture 25 °C 30...45 °C Set during manufacture 40 °C 36...53 °C Set during manufacture 48 °C 45...65 °C Set during manufacture 55 °C
Control accuracy	± 1 K
Differential pressure	Max. 2 bar
Δp hot-cold water	
Flow rate	see diagram
Connection size	1/2" - 2" (TM3400) DN65 - DN80 (TM3410)

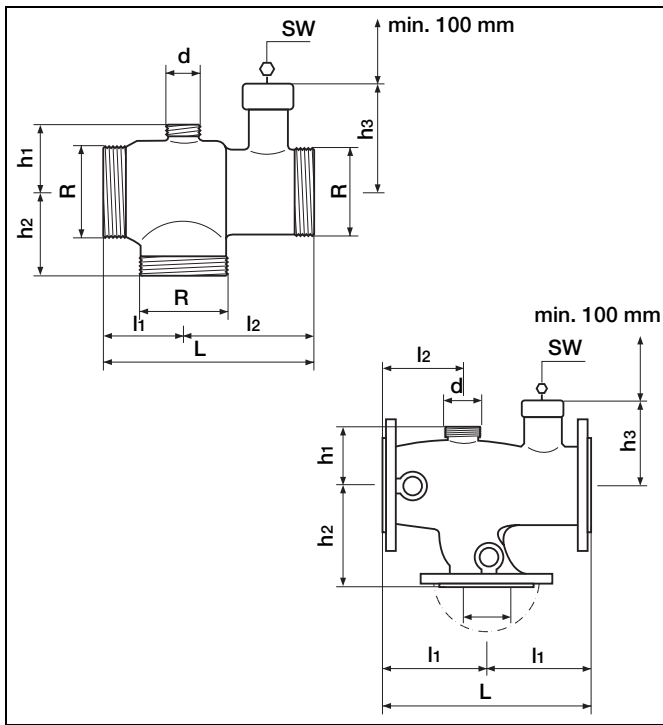

Method of Operation

The highly sensitive thermal element located in the outlet of the mixing valve controls a plug which regulates the flow proportions of cold and hot water in relation to the mixed hot water setting selected.

Options

Setting range 20...30 °C Set during manufacture 25 °C

- TM3400.910 with external thread connections 1/2"
- TM3400.920 with external thread connections 3/4"
- TM3400.930 with external thread connections 1"
- TM3400.940 with external thread connections 1 1/4"
- TM3400.950 with external thread connections 1 1/2"
- TM3400.960 with external thread connections 2"
- TM3410.601 with flange connections DN65, PN10 VSM/DIN
- TM3410.801 with flange connections DN80, PN10 VSM/DIN

Setting range 30...45 °C Set during manufacture 40 °C

- TM3400.912 with external thread connections 1/2"
- TM3400.922 with external thread connections 3/4"

- TM3400.932 with external thread connections 1"
- TM3400.942 with external thread connections 1 1/4"
- TM3400.952 with external thread connections 1 1/2"
- TM3400.962 with external thread connections 2"
- TM3410.605 with flange connections DN65, PN10 VSM/DIN
- TM3410.805 with flange connections DN80, PN10 VSM/DIN

- TM3400.964 with external thread connections 2"
- TM3410.606 with flange connections DN65, PN10 VSM/DIN
- TM3410.806 with flange connections DN80, PN10 VSM/DIN

Setting range 45...65 °C Set during manufacture 55 °C

- TM3400.916 with external thread connections 1/2"
- TM3400.926 with external thread connections 3/4"
- TM3400.936 with external thread connections 1"
- TM3400.946 with external thread connections 1 1/4"
- TM3400.956 with external thread connections 1 1/2"
- TM3400.966 with external thread connections 2"
- TM3410.608 with flange connections DN65, PN10 VSM/DIN
- TM3410.808 with flange connections DN80, PN10 VSM/DIN

Setting range 36...53 °C Set during manufacture 48 °C

- TM3400.914 with external thread connections 1/2"
- TM3400.924 with external thread connections 3/4"
- TM3400.934 with external thread connections 1"
- TM3400.944 with external thread connections 1 1/4"
- TM3400.954 with external thread connections 1 1/2"

Connection size	R	1/2"	3/4"	1"	1 1/4"	1 1/2"	2"		
	DN							65	80
Dimensions	(mm)								
	L	90	100	110	130	150	180	290	310
	l ₁	35	40	43	52	58	70	145	155
	l ₂	55	60	67	78	92	100	-	-
	h ₁	-	32	36	41	50	60	82	92
	h ₂	35	40	43	52	58	70	145	155
	h ₃	47	49	51	75	77	85	121	127
	d	-	1/2"	3/4"	3/4"	3/4"	3/4"	3/4"	1 1/2"
SW	5	5	5	5	5	5	5	8	8
Weight	approx. kg	0.57	0.65	0.87	1.60	2.10	3.37	23.00	28.00

Installation Example

MT = Thermostatic mixer TM3400- TM3410
 Vb1-Vb2 = Kombi-4 balancing valve

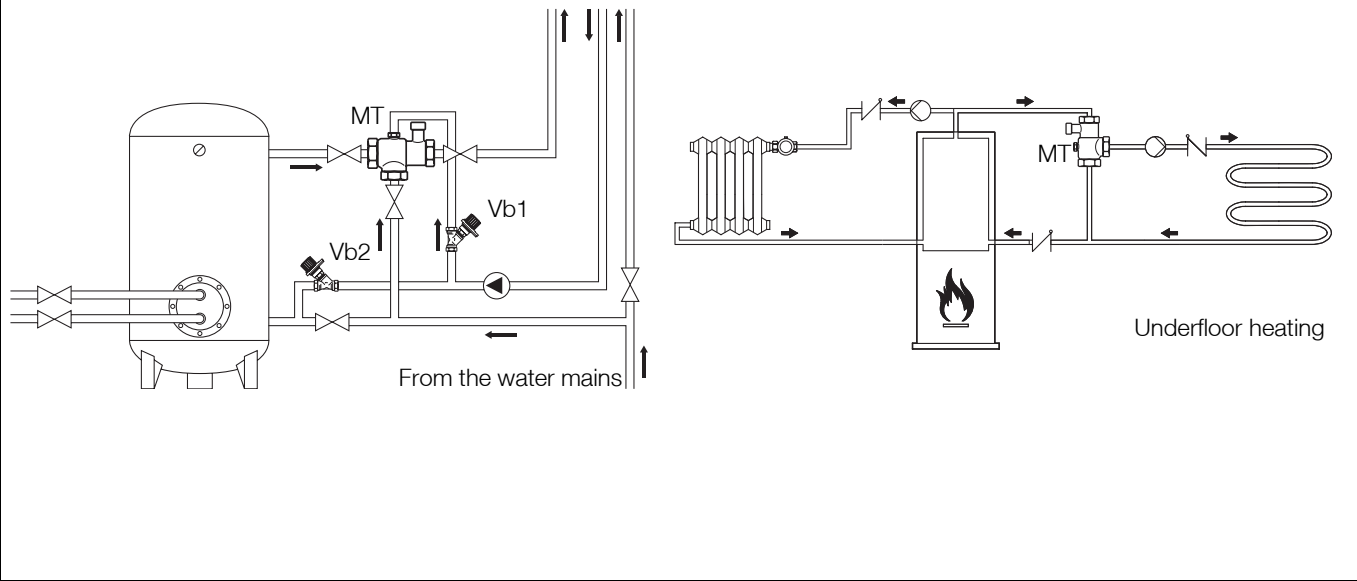

Installation Guidelines

- The thermostatic mixing valves can be installed in any position
- With any connections to be welded, during welding remove the mixer so as not to damage the thermostat and seals
- It is recommended that interception valves are installed on the connection ways to the mixer
- The polystyrene packaging may be used as insulation for the valve

Typical Applications

Due to the special features of standard TM3400 - TM3410 thermostatic mixing valves they are used in all installations where a temperature control of mixed water is required with a high precision of adjustment. Suitable for installation in water supply systems and also in industrial and commercial installations

The following are some typical applications:

- private individual or multiple family residences
- rest homes
- day-care centres and schools
- hotels and campsites
- businesses
- barracks
- industrial and commercial buildings
- sports centres and swimming pools
- alternative energy systems

Flow Diagram

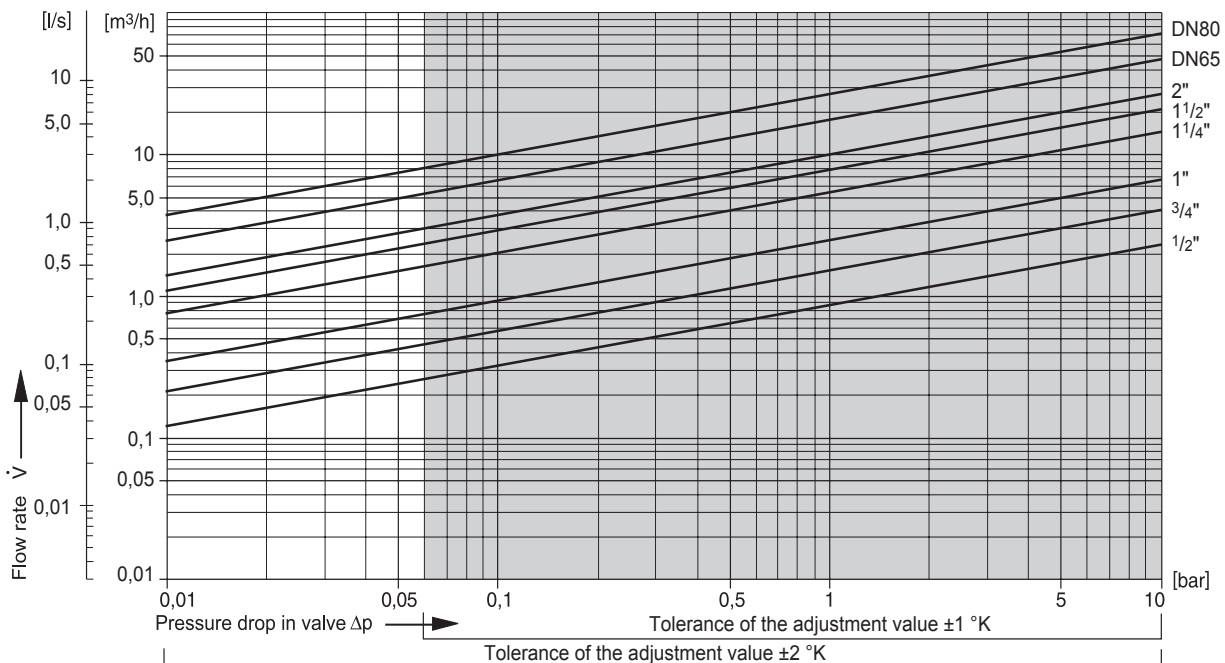

EN0H-1369GE23 R0610 • Subject to change

Automation and Control Solutions

Honeywell GmbH
Hardhofweg
D-74821 Mosbach
Phone: (49) 6261 810
Fax: (49) 6261 81309
<http://europe.hbc.honeywell.com>
www.honeywell.com

Manufactured for and on behalf of the
Environmental and Combustion Controls Division
of Honeywell Technologies Sàrl, Z.A. La Pièce 16,
1180 Rolle, Switzerland by its Authorised Repre-
sentative Honeywell GmbH

EN0H-1369GE23 R0610
Subject to change without notice
© 2010 Honeywell GmbH

Honeywell