



Thermal Actuators

STS61..

for small, zone and radiator valves

- **AC 24 V operating voltage, DC 0...10 V positioning signal**
- **Positioning force 105 N**
- **For direct mounting with union nut, no tools required**
- **Standard versions with 2 m, 5m and 10m connecting cable**
- **3-wire connection**
- **Direction of action can be selected by making appropriate electrical connection**
- **Position indication**
- **Robust construction**
- **Maintenance-free**

Use

- For Siemens small valves VVP47.., VXP47.. and VMP47..
- For Siemens small valves VD1..CLC
- For Siemens radiator valves VDN.., VEN.. and VUN..
- For Siemens MiniCombiValves (MCV) VPD.. and VPE..
- For Siemens zone valves V..I46..
- For Siemens small valves V..P469 (OEM), 599.. (U.S.)
- For radiator valves supplied by Heimeier, Cazzaniga, Oventrop M30 x 1.5, Honeywell-Braukmann, MNG, TA-type TBV-C, Junkers and Beulco new (all without adapter)
- For radiator valves with actuators secured with an M30 x 1.5 union nut, nominal closing dimension 11.6 mm and nominal stroke 2.5 mm (without adapter)
- With the appropriate adapters, the actuators can be used with valves of other manufacture (refer to "Type summary / Accessories", page 2)

Type summary

Type	Operating voltage	Positioning time at 20 °C	Dead time	Positioning signal	Connecting cable
STS61	AC 24 V	18...30 s/mm	80 s ¹⁾	DC 0...10 V	2 m
STS61/50					5 m
STS61/100					10 m
STS61S					2 m, non halogen

¹⁾ Max. dead time at cold start

Accessories

Adapter type	For valve makes	Adapter type	For valve makes
AV51	Beulco old (M30 x 1.0)	AV56	Giacomini
AV52	Comap	AV57	Herz
AV53	Danfoss RA-N (RA2000)	AV58	Oventrop old (M30 x 1.0)
AV54	Danfoss RAVL	AV59	Vaillant
AV55	Danfoss RAV	AV60	TA ¹⁾
		AV61	Markaryd

¹⁾ No adapter required for TBV-C type

Order

When ordering, please give quantity, product name and type reference.

Example: 1 actuator STS61 and
1 adapter AV55

Delivery

The valves, actuators and accessories are supplied in separate packages.

Equipment combinations

Valve type	Description		k_{vs} [m ³ /h]	\dot{V} [l/h]	PN class	Data sheet
VVP47.., VXP47 .., VMP47..	Small valves	NC	0.25...4.0		PN 16	N4847, N4850
VD1..CLC	Small valves	NO	0.25...2.6			N2103
VDN.., VEN.., VUN.. ¹⁾	Radiator valves	NO	0.09...1.4	25...483	PN 10	N2105, N2106
VPD.., VPE..	MiniCombiValves MCV	NO				N2185
VVI46.., VXI46..	Zone valves	NO	2...5		PN 16	N4842
VVS46.., VXS46..	Zone valves	NO	2...5			
V..P469 / 599..	Small valves	NO	0.25...4.0			
For other radiator valves without adapters (M30 x 1.5):						
<ul style="list-style-type: none"> • Heimeier • Cazzaniga • Oventrop M30 x 1.5 (from 2001) • Honeywell-Braukmann • MNG • TA-Type TBV-C • Junkers • Beulco new 						
For other radiator valves with AV.. adapters, refer to "Type summary / Accessories"						

¹⁾ Quasi-proportional control, not recommended for parallel operation
 k_{vs} = Nominal flow rate of cold water (5 to 30 °C) through the fully opened valve (H_{100}) at a differential pressure of 100kPa (1bar)
 \dot{V} = Volumetric flow
 NO= Normally open, valve is open without actuator
 NC= Normally closed, valve is closed without actuator

Function

The heating element with its solid expansion material converts the electrical positioning signal to linear travel of the valve stem. This causes the stem to extend or retract, opening or closing the valve, depending on the type of valve.

The STS61 actuator has no rotating parts, ensuring noiseless and wear- and tear-free operation.

Depending on the connection of the positioning signal (Y↑ or Y↓), the actuator offers 2 directions of action. It is therefore suited for both NO radiator valves, VD1..CLC small valves, MiniCombiValves and NC small valves, for example V..P47..

Operation				Breakdown
Direction of action	Positioning signal DC 0...10 V	Actuator stem	Valve behaviour	Actuator without operating voltage
↑	Y↑ increasing	Retracted	NO opens	NO radiator valve, VD1..CLC small valve or MCV closed
↓	Y↓ increasing	Extended	NC opens	NC small valve fully open

Operation

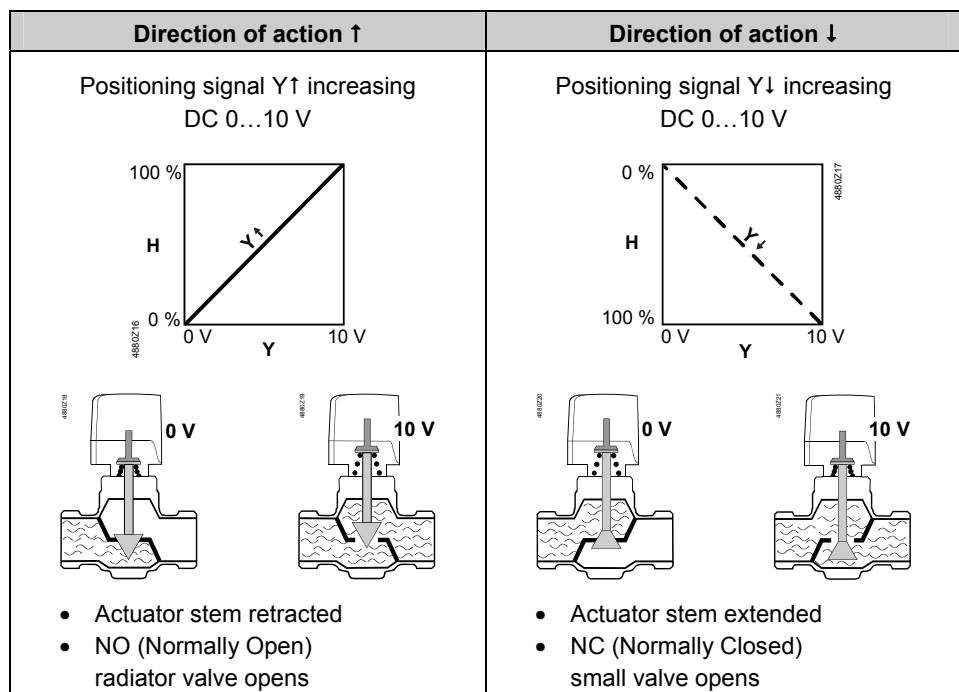

Breakdown

When there is no positioning signal DC 0...10 V and a power failure (AC 24 V missing), the actuator stem is always extended.

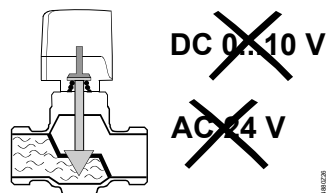

NO radiator valve
The radiator valve is closed.

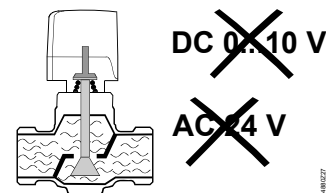

NC small valve
The small valve is opened.



Warning

When the actuator is de-energized, small valve types V..P47.. are fully opened.

Warning

When there is no positioning signal DC 0...10 V but AC 24 V operating voltage is applied, the actuator stem is extended to 50 % stroke.

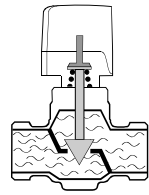

~~DC 0...10 V~~
AC 24 V

NO radiator valve

The radiator valve is partly opened.
Stroke H = 50%

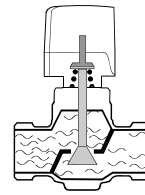

~~DC 0...10 V~~
AC 24 V

NC small valve

The small valve is partly opened.
Stroke H = 50%

Position indication

The valve position is indicated by a blue bar which moves up and down with the actuator stem.

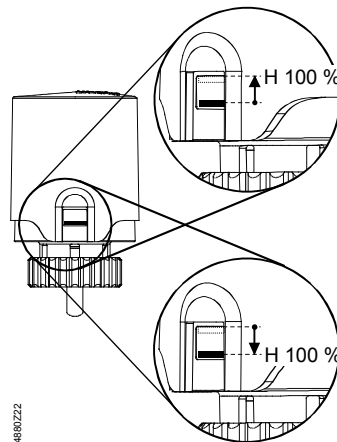

Direction of action ↑

In this position, the actuator is de-energized or Y↑ is 0 V. The actuator stem is extended and the NO radiator valve is closed.

Direction of action ↓

In this position

- the positioning signal Y ↓ is 10 V or
- there is a power failure or
- the positioning signal is missing.

The actuator stem is extended and the NC small valve is open.

Positioning times opening / closing

The positioning time depends on the voltage and the ambient temperature. In control mode, the stroke changes at a rate of 18...30 s/mm. This speed depends on the last stroke change, the voltage and the ambient temperature. The stroke change is acquired electronically and the actuator stopped when the required position is reached.

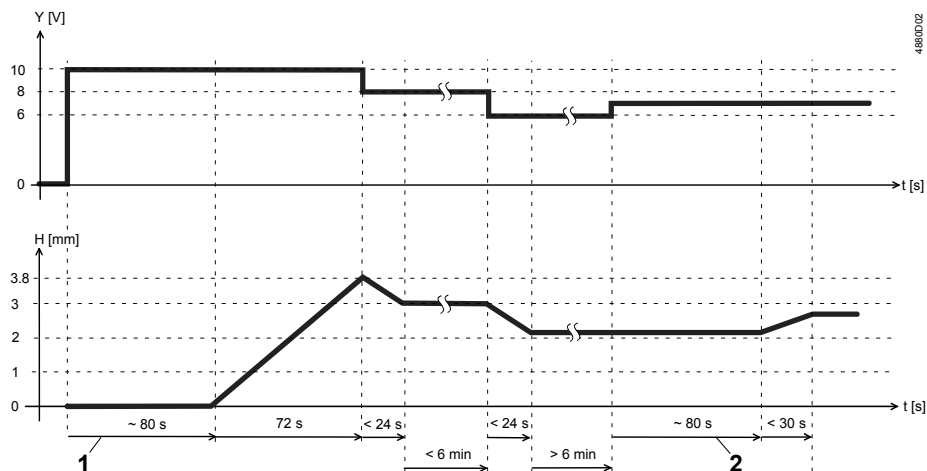

- 1 When cold, the actuator responds after a dead time of about 80 seconds.
- 2 In operation with no positioning signal change for 6 minutes, the same dead time of 80 seconds applies.

If, with direction of action ↑, the positioning signal drops below 0.3 V, or with direction of action ↓, exceeds 9.7 V, the actuator requires the dead time before control is started.

Accessories

Adapter type AV.. for third-party valves

Adapter types AV51 to AV61 are available for mounting the STS61 actuators on third-party radiator valves as shown under "Type summary / Accessories", page 2.

Tamper-proof fitting AL41/ AL40

Because of the overall dimensions of the actuator's union nut, this tamper-proof fitting can not be used.

Engineering notes

One of the electrical connections is not used, depending on the required direction of action.



The relevant wire must not be connected and is to be insulated.

Direction of action ↑

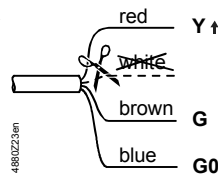

Direction of action ↓

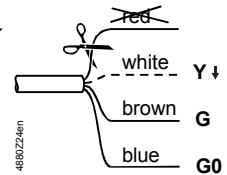

Mounting and installation notes

Mounting Instructions 74 319 0485 0 are included in the packaging.

Valve and actuator are easy to assemble on site before commissioning:

- Remove the protective cover from the valve body.
- Put the actuator in position and tighten the union nut manually.
- **Do not use pipe wrenches, spanners or similar!**
- The packaging can be used as a temporary cover for protection from dust etc.

Warning

Orientation

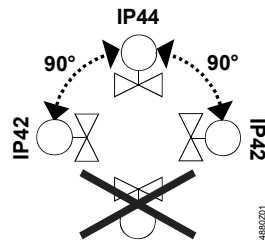

Notes on electrical installation

- Installation must be carried out in compliance with local installation regulations.
- The cable must be connected downwards so that it leads away from the bottom.
- If fluorescent lamps are used, separate load circuits are required to provide protection against overvoltage.
- Magnets can damage the actuator.
- A means of isolation from the power supply must be provided, for example by connecting an automatic circuit breaker or switch fuse upstream of the control unit.

Maintenance

STS61 actuators are maintenance-free.

Repair

Faulty actuators must be replaced as complete units. The actuator will be destroyed when opened. Exchange of the connecting cable is not permitted.

Disposal



The device contains electrical and electronic components and must not be disposed of as domestic waste. This applies in particular to the PCB.

Legislation may demand special handling of certain components, or it may be sensible from an ecological point of view.

Current local legislation must be observed.

Warranty

The technical data relating to specific applications are valid only in conjunction with the Siemens and third-party valves listed under "Equipment combinations", page 2.

If the STS61 actuators are used with third-party valves, the user is responsible for ensuring correct functioning.

Technical data

		STS61..	
Power supply	Operating voltage (low voltage ¹⁾)	AC 24 V	
	Voltage tolerance	± 20 %	
	Frequency	50 / 60 Hz	
	Power consumption operating on power-up	3 W 6 VA	
	Switch-on current (transient)	230 mA	
	Primary fuse	external	
Control	Positioning signal	DC 0...10 V	
	Input impedance for DC 0...10 V	$R_i \geq 800 \text{ k}\Omega$	
	Parallel operation	max. 10 pieces ²⁾	
Functional data	Positioning time at 20 °C, 2.5 mm stroke	< 75 s + max. 80 s dead time	
	Nominal stroke	3.8 mm	
	Positioning force	105 N	
	Permissible temperature of medium in the connected valve	1...110 °C	
	Actuator de-energized - NO radiator valves, VD1..CLC small valves, MCV - zone valve V..46.. - NC small valves	actuator stem extended - valve closed - control path open	
	Electrical connection	Connecting cable (integral)	stranded wire / 4 x 0.25 mm ²
		Cable length STS61, STS61S	2 m
STS61/50		5 m	
STS61/100		10 m	
Mounting	Fixing on valve	union nut M30 x 1.5	
	Orientation	Upright to horizontal; do not suspend	
Norms and standards	Meets requirements for CE marking: EMC directive	89/336/EEC	
	Immunity	EN 61000-6-1 Residential EN 61000-6-2 Industrial	
	Emission	EN 61000-6-3 Residential EN 61000-6-4 Industrial	
	Surge voltage	EN 61000-4-5, Class II	
	Electrical safety	SELV (PELV to IEC364-364-4-41)	
	Protection standard to EN 60730	Class II	
	Contamination level to EN 60730	Class 2	
	Housing protection standard		
	Mounted upright	IP 44 to EN 60529	
	Other orientation to horizontal	IP 42 to EN 60529	
	Suspended orientation	not allowed	
	Environmental compatibility	ISO 14001 (Environment) ISO 9001 (Quality) SN 36350 (Environmentally compatible products) RL 2002/95/EG (RoHS)	
	Dimensions / weight	Dimensions	refer to «Dimensions», page 8
Weight		0.18 kg	
Materials	Housing	PC Lexan 3412R with 20 % GF RAL7035	
	Cover Siemens	PC Lexan 940 RAL9010	

¹⁾ Only admissible with extra low voltage (SELV, PELV)

²⁾ Max. 60 VA when switching on

General environmental conditions

	Operation IEC 721-3-3	Transport IEC 721-3-2	Storage IEC 721-3-1
Environmental conditions	Class 3K3	Class 2K3	Class 1K3
Temperature	-5...+50 °C	-20...+60 °C	+5...+50 °C
Humidity	5...95 % r.h.	5...95 % r.h.	5...95 % r.h.

Connecting cable

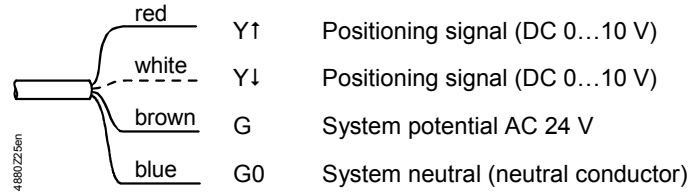

Connection diagrams

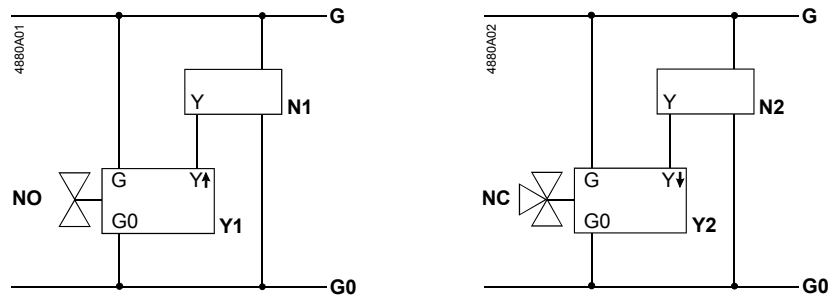

- Y Positioning signal DC 0...10 V
- N Controller
- Y1, Y2 Actuator
- NO Valve (Normally Open)
- NC Valve (Normally Closed)
- G System potential AC 24 V
- G0 System neutral

Dimensions

Dimensions in mm

