

Room Temperature Controller with LCD

RDF20

for 2-pipe fan coil units with electrical heater

for compressors in DX type equipment with electrical heater

Outputs for an on / off valve actuator and an electrical heater

Outputs for a 1-stage compressor and an electrical heater

Outputs for a 3-speed fan

Control depending on the room or the return air temperature

Automatic heating / cooling changeover

Operating modes: Normal, Economy and Standby

Operating mode changeover input for remote control

Function for avoiding damage resulting from moisture

Selectable installation and control parameters

Display of room temperature or setpoint selectable

Minimum and maximum setpoint limitation

Operating voltage AC 230 V

Use

Typical use:

- For control of the room temperature in individual rooms that are heated or cooled with 2-pipe fan coil units equipped with an electrical heater
- For the control of rooms that are heated or cooled with DX type equipment and an electrical heater
- For opening or closing a valve
- For switching an electrical heater
- For switching a 3-speed fan

The controller acquires the room temperature via its integrated sensor or external room temperature sensor (QAA32) or, if used, via an external return air temperature sensor (QAH11.1) and maintains the setpoint by delivering 2-position valve control or compressor output commands.

The switching differential is 2 K in heating mode and 1 K in cooling mode (adjustable parameters).

Fan operation

The fan is switched to the selected speed via control output Q1, Q2 or Q3. When function "Temperature-dependent fan control" is activated (can be selected with DIP switch no.1), the fan is switched on / off depending on the temperature, that is, together with the valve or compressor.

It is switched off when

- leaving the heating or cooling sequence, provided function "Temperature-dependent fan control" is activated, or
- manually changing to Standby "⏻", provided no setpoints (e.g. for frost protection mode) are set and active
- activating an external operating mode changeover switch, provided plant conditions do not call for Economy mode
- turning off the controller's power supply

Note

To avoid over temperatures of the electrical heater or to prevent the thermal cut-out from responding, the fan will overrun for 60 seconds (parameter P21) when the electrical heater is switched off.



In the event of failure, the RDF20 cannot protect the electrical heater against over temperatures. For this reason, the electrical heater must be equipped with a separate safety device (thermal cutout).

Display

If DIP switch no. 2 is set to ON (factory setting), the controller displays the acquired room or return air temperature (unless parameter or setpoints are temporarily changed). If the DIP switch is set to OFF, the controller displays the normal operation mode setpoint. In this case, the value of the current temperature reading can only be visualized temporarily by selecting parameter P14.

Water-based fan coil application

Used in conjunction with 1 valve, either for heating / cooling with changeover, heating only or cooling only operation.

The valve receives the **OPEN** command via control output Y11 when

ON

1. the acquired room temperature lies by half the switching differential below the setpoint (heating mode) or above the setpoint (cooling mode), and
2. the valve has been fully closed for more than 1 minute (parameter P20).

OFF

The valve receives the **CLOSE** command via control output Y11 when

1. the acquired room temperature lies by half the switching differential above the setpoint (heating mode) or below the setpoint (cooling mode), and
2. the valve has been fully open for more than 1 minute (parameter P19).

Note: Control output Y12 delivers a control command which is inverted to the control command at output Y11 and which can be used for normally open valves.

Automatic changeover

The water temperature acquired by the changeover sensor (QAH11.1 + ARG86.3) is used by the controller to switch from heating to cooling mode, or vice versa. When the water temperature lies above 28 °C (parameter P08), the controller switches to heating mode, below 16 °C (parameter P07) it switches to cooling mode. If, immediately after switching on, the water temperature lies between the 2 changeover points, the controller will start in heating mode. The water temperature is acquired at 30-second intervals and the operating state is updated.

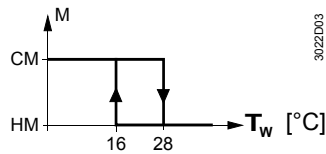

CM	Cooling mode
HM	Heating mode
M	Operating mode
T _w	Water temperature

Purging function (optional)

The task of the changeover sensor is to initiate the change from heating to cooling mode, based on the acquired water temperature. If a 2-port valve is used, it is highly recommended to activate the purging function (parameter P16). This function ensures the correct acquisition of the medium temperature even if the 2-port valve is closed for a longer period of time. To achieve this, the valve is opened for 1 to 5 minutes (parameter P16) at 2-hour intervals during off hours.

When the purging function is activated, the first purging action is performed after changing parameter P16 and quitting the parameter setting mode.

If the RDF20 is used for compressor-based applications, the purging function (parameter P16) must remain disabled.

Compressor-based application

Used in conjunction with a 1-stage compressor for cooling only or heating only operation with an electrical heater.

ON

The compressor receives the **ON** command via control output Y11 when

1. the acquired room temperature lies by half the switching differential below the setpoint (heating mode) or above the setpoint (cooling mode), and
2. the compressor has been **OFF** for more than 1 minute (parameter P20).

OFF

The compressor receives the **OFF** command via control output Y11 when

1. the acquired room temperature lies by half the switching differential above the setpoint (heating mode) or below the setpoint (cooling mode), and
2. the compressor has been **ON** for more than 1 minute (parameter P19).

Return air temperature (optional)

The RDF20 provides control either depending on the acquired room temperature or depending on the fan coil unit's return air temperature. Changeover is automatic if a QAH11.1 cable temperature sensor is connected.

Electrical heating, active in heating mode

(Note: This function is not active when using thermal actuators).

In addition to hot water heating, the electrical heater receives an **ON** command via Y21 when

1. the acquired room temperature is $x \leq w - w_D - \frac{1}{2} \text{SDH}$, and
2. the electrical heater has been switched off for more than 1 minute.

The **OFF** command for the electrical heater is given when

1. the acquired room temperature is $x \geq w - w_D + \frac{1}{2} \text{SDH}$, and
2. the electrical heater has been switched on for more than 1 minute.

Electrical heating, active in cooling mode

For this operation, DIP switch no. 4 must be set to **ON** (factory setting).

The electrical heater receives the ON command via control output Y21 when

1. the acquired room temperature lies by half the switching differential below the adjusted setpoint, and
2. the electrical heater has been switched off for more than 1 minute.

The **OFF** command for the electrical heater is given when

1. the measured room temperature lies by half the switching differential above the adjusted setpoint, and
2. the electrical heater has been switched on for more than 1 minute.

Heating mode (hot water plus electric heating)

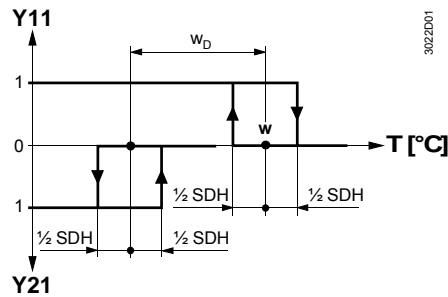

Cooling mode (chilled water) (DIP switch no. 4: OFF)

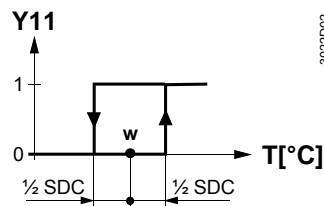

Cooling mode with optional electrical heating (DIP switch no. 4: ON)

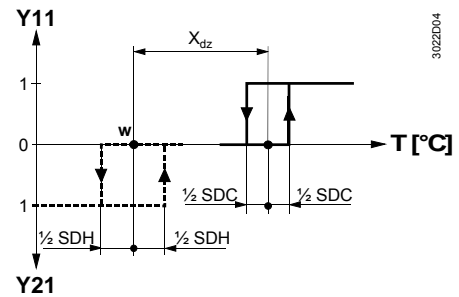

T[°C]	Room temperature
w	Room temperature setpoint
w _D	Setpoint differential
Y11	Manipulated variable "Valve" or "Compressor"
Y12	Reverse of Y11
Y21	Manipulated variable "Electrical heating"
SDH	Switching differential "Heating"
SDC	Switching differential "Cooling"
Xdz	Dead zone

Operating modes

The following operating modes are available:

Normal mode

Heating or cooling mode with automatic changeover and with manually selected fan speed III, II or I. In Normal mode, the controller maintains the adjusted setpoint.

Economy mode

A changeover switch can be connected to status input «D1-GND». When the switch closes its contact (due to an open window, for instance), the operating mode will change from Normal mode to Economy mode. In this operating mode, the relevant setpoints of heating or cooling are maintained (control parameters P01 and P02). The operating action of the switch (NC or NO) can be selected.

Standby

The relevant setpoints of heating and cooling are maintained when in Standby "⏸", provided such setpoints have been adjusted (parameters P03 and P04).

Avoiding damage due to moisture (optional)

To avoid damage due to moisture in very warm and humid climatic zones resulting from lack of air circulation in Economy mode (e.g. in hotel rooms during unoccupied periods), the fan can be kept running in Economy mode when activating parameter P17. In this case, the fan keeps running at the selected speed or at speed 1 if the operating mode selector is in Standby "⏸".

Setting the control parameters

A number of control parameters can be set to optimize the control performance. These parameters can also be set during operation without opening the unit. In the event of power failure, all control parameters set will be maintained.

Settings

The parameters can be changed as follows:

1. Set the operating mode selector to Standby "⏸".
2. Press buttons + and - simultaneously for 3 seconds. Release them and, within 2 seconds, press button + again for 3 seconds. Then, the display will show "P01".
3. Select the required parameter by repeatedly pressing buttons + and - :

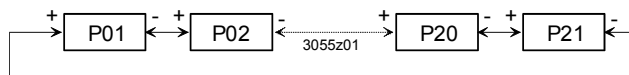

4. By pressing buttons + and – simultaneously, the current value of the selected parameter appears, which can be changed by repeatedly pressing buttons + and –.
5. By pressing buttons + and – simultaneously again or 5 seconds after the last press of a button, the last parameter will be displayed again.
6. If you wish to display and change additional parameters, repeat steps 3 through 5.
7. 10 seconds after the last display or setting, all changes will be stored and the controller returns to normal operation.

Control parameters

Parameter	Meaning	Setting range	Factory setting
P01	Setpoint of heating in Economy mode (operating mode changeover contact activated)	OFF, 5...20 °C (in increments of 0.5 K)	16 °C
P02	Setpoint of cooling in Economy mode (operating mode changeover contact activated)	OFF, 21...35 °C (in increments of 0.5 K)	28 °C
P03	Setpoint of heating in Standby “⏻”	OFF, 5...20 °C (in increments of 0.5 K)	8 °C
P04	Setpoint of cooling in Standby “⏻”	OFF, 21...35 °C (in increments of 0.5 K)	OFF
P05	Minimum setpoint limitation in Normal mode	5...20 °C (in increments of 0.5 K)	5 °C
P06	Maximum setpoint limitation in Normal mode	21...35 °C (in increments of 0.5 K)	35 °C
P07	Heating / cooling changeover switching point cooling	10...25 °C (in increments of 0.5 K)	16 °C
P08	Heating / cooling changeover switching point heating	27...40 °C (in increments of 0.5 K)	28 °C
P09	Sensor calibration	-3...+3 °C (in increments of 0.5 K)	0 K
P10	P-band in heating mode or switching differential heating	0.5...+4 K (in increments of 0.5 K)	2 K
P11	P-band in cooling mode or switching differential cooling	0.5...+4 K (in increments of 0.5 K)	1 K
P12	Dead zone in Normal mode	0.5...5 K (in increments of 0.5 K)	2 K
P13	Active temperature sensor (no setting, display only)	1: Room temperature sensor active 2: Return air temperature sensor active	-
P14	Value of current room temperature reading (no setting, display only)	0...49 °C = current temperature value	-
P15	Value of current heating / cooling changeover temperature reading including indication of current mode (⚙️, ⏻) (no setting, display only)	100 = input open (no sensor connected, heating mode (⏻)) 0...49 °C = current temperature value 00 = input bridged, cooling mode (⚙️)	-
P16	Purging function	0 min.: Not active 1...5 min.: Active with selected duration	0 min
P17	Fan control in Economy mode OFF: Fan is off in the dead zone / ON: Fan is on in the dead zone	ON: Running in selected speed or in speed one if in Standby “⏻”	OFF
P18	Setpoint differential	0.5...5 K	2 K
P19	Minimum output on time (Y11, Y21)	1...20 minutes (in increments of 1 min.)	1 min.
P20	Minimum output off time (Y11, Y21)	1...20 minutes (in increments of 1 min.)	1 min.
P21	Fan overrun	0...300 seconds (in increments of 10 s)	60 s

Ordering

When ordering, please give name and type reference.

The QAH11.1 temperature sensor (can be used as a return air temperature or change-over sensor), the changeover sensor mounting kit and the valves are to be ordered as separate items.

Equipment combinations

Type of unit	Type reference	Data Sheet
Cable temperature sensor	QAH11.1	1840
Room sensor	QAA32	1747
Changeover mounting kit	ARG86.3	1840
Electromotoric on / off actuator	SFA21...	4863
Thermal actuator (for radiator valve)	STA21...	4893
Thermal actuator (for small valves 2.5mm)	STP21...	4878

Mechanical design

The controller consists of 2 parts:

- Plastic housing which accommodates the electronics, the operating elements and the built-in room temperature sensor
- Base





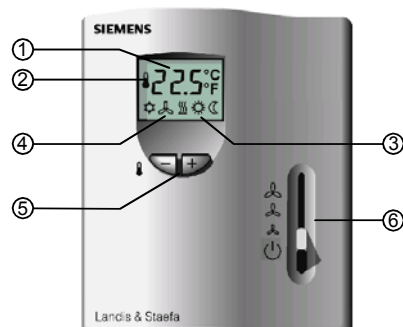

The housing engages in the base and is secured with 2 screws.

The base carries the screw terminals. The DIP switches are located at the rear of the housing.

Setting and operating elements



Legend

- 1 Display of the room temperature, setpoints or control parameters
- 2  Symbol used when displaying the current room temperature
- 3  Normal mode
 Economy mode
- 4  Cooling valve open
 Fan on
 Heating valve open
- 5 Buttons for adjusting the setpoints and the control parameters
- 6 Operating mode selector
(Standby “”, heating or cooling mode with manual selection of the fan speed)

Set of DIP switches

DIP switch no.	Meaning	Position ON (factory setting)	Position OFF
1	Fan control	Fan control is temperature-independent in normal operation	Fan control is temperature-dependent in all operating modes
2	Display of temperature or setpoint	Room (or return air) temperature display	Setpoint display
3	Operating action of switch for external operating mode changeover	Changeover activated when switch is closed (NO)	Changeover activated when switch is open (NC)
4	Electrical heater	Active in cooling mode	Inactive in cooling mode

Accessories

Description	Type reference
Adapter plate 120 x 120 mm for 4" x 4" conduit boxes	ARG70
Adapter plate 96 x 120 mm for 2" x 4" conduit boxes	ARG70.1
Adapter plate for surface wiring 112 x 130 mm	ARG70.2

Engineering notes

In systems without automatic changeover, the temperature sensor can be replaced by an external switch (suited for mains voltage) for manual changeover.

In systems with continuous heating mode, no sensor is connected to the controller's input.

In systems with continuous cooling mode, the controller input (B2-M) must be bridged.

Mounting, installation and commissioning notes

Mounting location: On a wall or inside the fan coil unit. Not in niches or bookshelves, not behind curtains, above or near heat sources and not exposed to direct solar radiation. Mounting height is about 1.5 m above the floor. The connecting wires can be run to the controller from a recessed conduit box.

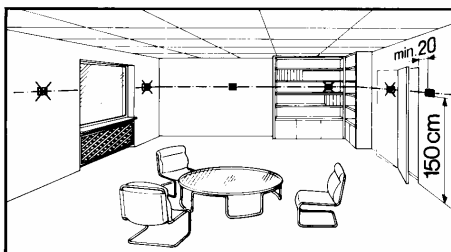

Check the positions of the DIP switches and change them, if required.

After applying power, the controller makes a reset during which all LCD segments flash, indicating that the reset has been correctly made. This takes about 3 seconds. Then, the controller is ready to operate.

- Prior to fitting the changeover sensor, thermal conductive paste must be applied to the location on the pipe where the sensor placed
- The cables used must satisfy the insulation requirements with regard to mains potential
- Sensor inputs B1-M and B2-M carry mains potential. If the sensor's cables are extended, they must be suited for mains voltage



The controller is supplied with Mounting Instructions.

Calibrating the sensor

If the room temperature displayed by the controller is inconsistent with the room temperature effectively measured, the temperature sensor can be recalibrated. In that case, parameter P09 must be changed.



Technical data

⚠ Power supply	Operating voltage	AC 230 V +10/-15 %
	Frequency	50/60 Hz
	Power consumption	max. 6 VA
	Control outputs Q1, Q2, Q3-N	AC 230 V
	Rating	max. 6(4)A
	Control output Y11-N (NO)	AC 230 V
	Rating	max. 5(3)A
	Control output Y12-N (NC)	AC 230 V
	Rating	max. 5(3)A
	Control output Y21-N (NO)	AC 230 V
	Rating	max. 5(3)A
	Return air temperature sensor – status input B1-M	QAH11.1, safety class II NTC resistor 3 kΩ at 25 °C
	Changeover – status input B2-M	QAH11.1, safety class II NTC resistor 3 kΩ at 25 °C
Operational data	Status input D1 and GND	
	Operating action selectable	normally open (NO) normally closed (NC)
	Contact sensing	SELV DC 6...15 V / 3...6 mA
	Insulation against mains	4 kV, reinforced insulation
	Perm. cable length with copper cable 1.5 mm ² for connection to terminals B1, B2 and D1	80 m
	Setpoint setting range	5...35 °C
	Control deviation at 25 °C	max. ±0.5 K
	Switching differential in heating mode (adjustable)	2 K
	Switching differential in cooling mode (adjustable)	1 K
	Dead zone X_{dz} in normal operation (adjustable)	2 K
	Setpoint differential w_D (adjustable)	2 K
	Setpoint «Economy mode (C)», heating (adjustable)	16 °C
	Setpoint «Economy mode (C)», cooling (adjustable)	28 °C
Environmental conditions	Setpoint «Standby (U)», heating (adjustable)	8 °C
	Setpoint «Standby (U)», cooling (adjustable)	OFF
	Operation	to IEC 721-3-3
	Climatic conditions	class 3 K5
	Temperature	0...+50 °C
	Humidity	<95 % r.h.
	Transport	to IEC 721-3-2
	Climatic conditions	class 2 K3
	Temperature	-25...+70 °C
	Humidity	<95 % r.h.
	Mechanical conditions	class 2M2
	Storage	to IEC 721-3-1
	Climatic conditions	class 1K3
Temperature	-25...+70 °C	
Humidity	<95 % r.h.	
Norms and standards	 conformity to	
	EMC directive	89/336/EEC
	Low voltage directive	73/23/EEC
 N474	C-Tick conformity to	
	EMC emission standard	AS/NSZ 4251.1:1994

General

Product standards	Automatic electrical controls for household and similar use Special requirements on temperature-dependent controls	EN 60 730 – 1 EN 60 730 – 2 - 9
Electromagnetic compatibility	Emissions Immunity	EN 50 081-1 EN 50 082-1
Devices of safety class		II to EN 60 730
Pollution class		normal
Degree of protection of housing		IP 30 to EN 60 529
Connection terminals		solid wires or prepared stranded wires 2 x 0.4-1.5 mm ² or 1 x 2.5 mm ²
Weight		0.23 kg
Colour of housing front		white, NCS S 0502-G (RAL9003)

Connection terminals

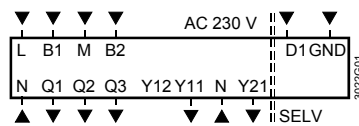

- L, N Operating voltage AC 230 V
- B1 Status input «Return air temperature sensor or external room temperature sensor QAA32»
- M Measuring neutral «Return air temperature sensor or external room temperature sensor QAA32» and «Changeover sensor»
- B2 Status input «Changeover sensor »

- D1, GND Status input for potential-free operating mode changeover switch (operating action can be selected)
- Q1 Control output "Fan speed I" AC 230 V
- Q2 Control output "Fan speed II" AC 230 V
- Q3 Control output "Fan speed III" AC 230 V
- Y11 Control output "Valve" AC 230 V (N.O. contact, for N.C. valves) or output for compressor
- Y12 Control output "Valve" AC 230 V (N.C. contact, for N.O. valves)
- Y21 Control output "Electrical heating" AC 230 V

Connection diagram

Application:

2-pipe fan coil units with electrical heater

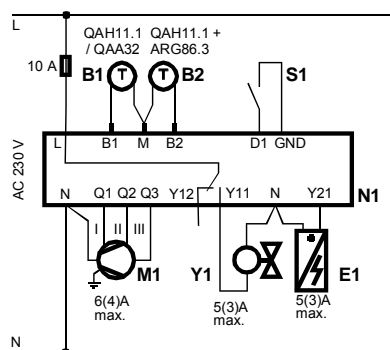

- B1 Return air temperature sensor (QAH11.1) or external room temperature sensor (QAA32)
- B2 Changeover sensor (temperature sensor QAH11.1 + changeover mounting kit ARG86.3)
- E1 Electrical heater
- M1 3-speed fan
- N1 Room temperature controller RDF20
- S1 External operating mode changeover switch
- Y1 Zone valve

Application:

Compressors in DX type equipment with electrical heater

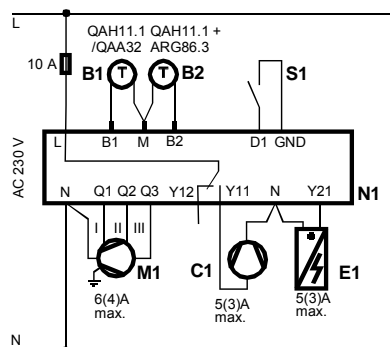

- B1 Return air temperature sensor (QAH11.1) or external room temperature sensor (QAA32)
- B2 Changeover sensor (temperature sensor QAH11.1 + changeover mounting kit ARG86.3)
- E1 Electrical heater
- M1 3-speed fan
- N1 Room temperature controller RDF20
- S1 External operating mode changeover switch
- C1 Compressor

Dimensions

Controller

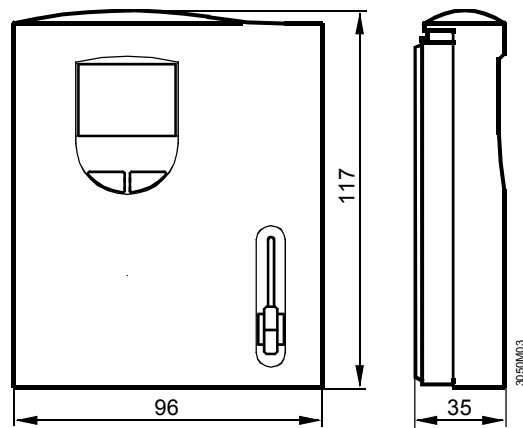

Base

