



Symaro™

## Room sensors

## QFA31...

for relative humidity (high accuracy) and temperature

- Operating voltage AC 24 V / DC 13.5...35 V
- Signal output DC 0...10 V / 4...20 mA for relative humidity and temperature
- Very high measuring accuracy across the entire measuring range
- Capacitive humidity measurement
- Function test
- Range of use  $-40...+70\text{ °C}$  /  $0...100\text{ % r. h.}$   
with LCD display  $-25...+70\text{ °C}$  /  $0...100\text{ % r. h.}$

### Use

The QFA31... is for use in ventilation and air conditioning plants where high accuracy and short response times for measuring relative humidity are required. The measuring range covers the entire humidity range of 0...100 %.

Examples:

- Storage and production facilities in the paper, textile, pharmaceutical, food, chemical and electronics industry, etc.
- Laboratories
- Hospitals
- Indoor swimming-pools
- Computer and EDP centers
- Greenhouses
- With the AQF3100 accessory for outdoor use

## Type summary

Type reference	Temperature measuring range	Temperature signal output	Humidity measuring range	Humidity signal output	Operating voltage	Measured value display
<b>QFA3100</b>	None	None	0...100 %	active, DC 0...10 V	AC 24 V or DC 13,5...35 V	No
<b>QFA3101</b>	None	None	0...100 %	active, 4...20 mA	DC 13,5...35 V	No
<b>QFA3160</b>	0...50 °C / -40...+70 °C / -35...+35 °C	active, DC 0...10 V	0...100 %	active, DC 0...10 V	AC 24 V or DC 13,5...35 V	No
<b>QFA3160D</b>	0...50 °C / -40...+70 °C / -35...+35 °C	active, DC 0...10 V	0...100 %	active, DC 0...10 V	AC 24 V or DC 13,5...35 V	Yes
<b>QFA3171</b>	0...50 °C / -40...+70 °C / -35...+35 °C	active, 4...20 mA	0...100 %	active, 4...20 mA	DC 13,5...35 V	No
<b>QFA3171D</b>	0...50 °C / -40...+70 °C / -35...+35 °C	active, 4...20 mA	0...100 %	active, 4...20 mA	DC 13,5...35 V	Yes

## Ordering and delivery

When ordering, please give name and type reference, e.g.: Room sensor **QFA3160**  
The outdoor mounting kit **AQF3100**, and the service set **AQF3153** listed under "Accessories" must be ordered as a separate item.

## Equipment combinations

All systems and devices capable of acquiring and handling the sensor's DC 0...10 V or 4...20 mA output signal.

When using the sensors for minimum or maximum selection, for averaging, or to calculate enthalpy, enthalpy difference, absolute humidity, and dew point, we recommend to use the SEZ220 signal converter (see Data Sheet N5146).

## Technical design

### Relative humidity

The sensor acquires the relative humidity in the room or in the outer air, respectively, via its capacitive sensing element whose capacitance varies as a function of the relative humidity of the ambient air.

An electronic circuit converts the sensor's signal to a continuous DC 0...10 V or 4...20 mA signal, corresponding to a relative humidity of 0...100 %.

### Temperature

The sensor acquires the temperature in the room or in the outer air, respectively, via its sensing element whose electrical resistance changes as a function of the temperature. This variation is converted to an active DC 0...10 V or 4...20 mA output signal, depending on the type of sensor. The output signal corresponds to a selectable temperature range of 0...50 °C, -35...+35 °C, or -40...+70 °C.

### Burden diagram

Output signal, terminal I1 / I2

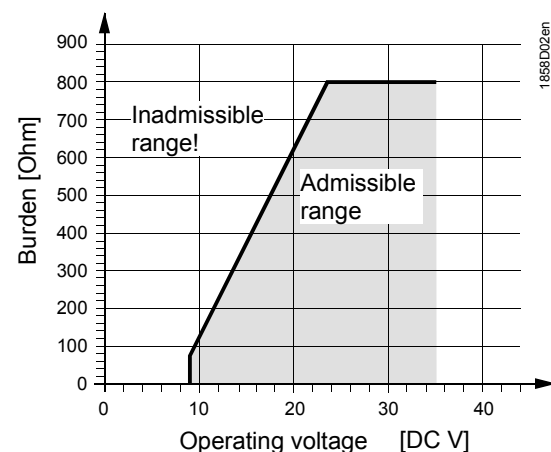

Room sensor QFA31...

The room sensor consists of a housing, a printed circuit board, connection terminals and a measuring tip. The two-part housing comprises a base and a screwed removable cover.

A rubber seal is installed between base and cover in order to satisfy the requirements of IP 65 degree of protection.

The measuring circuit and the setting element are accommodated on the printed circuit board inside the cover, the connection terminals in the base. Housing and measuring tip are screwed together. The measuring tip features a degree of protection of IP40. The sensing elements are located at the end of the measuring tip, protected by a screw-on filter cap.

Cable entry is made via the cable entry gland M16 supplied with the sensor, which screws into the housing.

If the sensor is used outdoors, that opening must be closed off and the prepared hole on the opposite side of the base knocked out.

Measured value display

The types QFA3160D and QFA3171D provide the measured values on its LCD display. The following measured values are displayed alternately in intervals of 5 s:

Temperature: in °C or °F  
 Humidity: in % r. h.

Setting elements

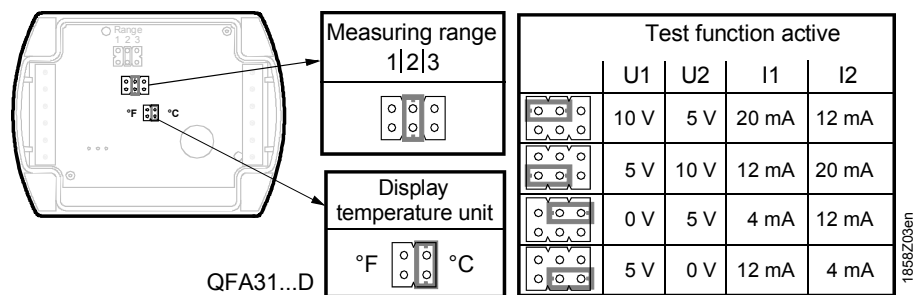

The setting elements are located inside the cover. A setting element consists of 6 pins and a jumper. It is used for selecting the required temperature measuring range and for activating the test function. Types with LCD display have a second setting element with 4 pins and a jumper.

The different jumper positions have the following meaning:

- *For the active temperature measuring range:*  
 Jumper in the left position (R1) = -35...+35 °C,  
 Jumper in the middle position (R2) = 0...50 °C (factory setting)  
 Jumper in the right position (R3) = -40...+70 °C
- *For the active test function:*  
 Jumper in the horizontal position: The values available at the signal output are those given in the table "Test function active".
- *For the measured value display (QFA31...D)*  
 - Jumper vertical in the right position = °C (factory setting)  
 - Jumper vertical in the left position = °F

Malfunction

- Should the temperature sensor become faulty a voltage of 0 V (4 mA) will be applied at signal output U2 (I2) after 60 seconds, and the humidity signal at signal output U1 (I1) will reach 10 V (20 mA).
- Should the humidity sensor become faulty a voltage of 10 V (20 mA) will be applied at signal output U1 (I1) after 60 seconds, and the temperature signal will remain active.

## Outdoor mounting kit AQF3100

The outdoor mounting kit consists of:

- 1 wall mounting bracket complete with radiation shield
- 4 Phillips-head screws K35 x 12
- 1 grommet M 16 x 1.5 with O-ring and nut M 16 x 1.5 for closing off the sensor's cable entry hole if not required

## Service set AQF3153

The service set comprises three measuring tips without sensor element. Each tip signals a predefined temperature and humidity value to the basic unit:

- 85 % r. h., 40 °C
- 50 % r. h., 23 °C
- 20 % r. h., 5 °C

The fixed values are available at the signal outputs. The accuracy is the same as for the test function. The measuring tips can be exchanged in operation.

## Accessories

<i>Name</i>	<i>Type reference</i>
Outdoor mounting kit (incl. radiation shield)	<b>AQF3100</b>
Filter cap (for replacement)	<b>AQF3101</b>
Measuring tip (exchangeable for replacement)	<b>AQF3150</b>
Service set (for function test)	<b>AQF3153</b>
3 m cable for remote measurement	<b>AQY2010</b>

## Engineering notes

A transformer for safety extra low-voltage (SELV) with separate windings for 100 % duty is required to power the sensor. All safety regulations valid at the location of the plant must be complied with when sizing and protecting the transformer.

When sizing the transformer, the sensor's power consumption must be taken into consideration.

For the electrical connection of the sensor, refer to the Data Sheets of the devices with which the sensor is used.

The maximum permissible cable lengths must be considered.

### Cable routing and cable selection

It must be considered for routing of cables that electrical interference is the greater, the longer the cables run side by side and the smaller the distance between them. Use shielded cables in environments having EMC problems.

Twisted pairs of cables are required for the secondary supply lines and the signal lines.

### Note to QFA3171(D)

Terminals G1(+) and I1(–) for the humidity output must always be connected to power, even if only terminals G2(+) and I2(–) of the temperature output are used!

## Mounting notes

### Interior mounting

#### QFA31... without AQF3100

#### Mounting location

Inside wall (not on outside wall!) of the room to be air conditioned; not in recesses, behind curtains, above or close to heat sources or shelves; not on walls behind which a chimney is located.

The sensor must not be exposed to direct solar radiation.

Install the sensor in the occupied space about 1.5 m above the floor and at least 50 cm from the next wall.

#### Caution!

- The seal between base and cover must not be removed, or else degree of protection IP 65 will be no longer ensured.
- The sensing elements inside the measuring tip are sensitive to shock and impact. Avoid any such impact on mounting.

Mounting position Without using the AQF3100 outdoor mounting kit, the sensor must not be mounted with the measuring tip pointing upward.

Mounting Instructions Mounting Instructions are printed on the inner side of the package.

### Outdoor mounting

#### QFA31... with AQF3100

Mounting location Exterior wall, preferably on the North or Northwestern side of the building; if possible in the middle of the wall, at least 2.5 above the ground.  
Not above or below windows, above doors and ventilation shafts, below balconies or eaves.

Mounting position The sensor with AQF3100 must be mounted in a vertical position (radiation shield at the top).

Mounting Instructions Mounting Instructions are enclosed with the AQF3100.

*Note* When using the AQF3100 outdoor mounting kit, the sensor's cable entry hole must be closed off with the grommet and the prepared M16 cable entry on the opposite side knocked out.

### Commissioning notes

Prior to switching on power, check wiring.  
On the sensor, select the required temperature measuring range.

Wiring and the output signals can be checked by making use of the test function (refer to "Mechanical design").



We recommend not to use voltmeters or ohmmeters directly at the sensing element. In the case of the simulated passive output signals, measurements with commercially available meters cannot be made (measuring current too small).

### Technical data

Power supply	Operating voltage	AC 24 V $\pm$ 20 % or DC 13.5...35 V
	Frequency	50/60 Hz at AC 24 V
	Power consumption	$\leq$ 1 VA
Cable lengths for the measuring signal	Max. perm. cable lengths	refer to Data Sheet of the device handling the signal
Functional data "Humidity sensor"	Measuring range	0...100 % r. h.
	Measuring accuracy at 23 °C and AC/DC 24 V in 0...100 % r. h.	$\pm$ 2 % r. h.
	Temperature dependency	$\leq$ 0.05 % r.h./°C
	Time constant	< 20 s
	Output signal, linear (terminal U1)	DC 0...10 V $\hat{=}$ 0...100 % r.h. max. $\pm$ 1 mA
	Output signal, linear (terminal I1) Burden	4...20 mA $\hat{=}$ 0...100 % r.h. refer to "Function"
	Functional data "Temperature sensor"	Measuring range
	Sensing element	Pt 1000
	Measuring accuracy at AC/DC 24 V in	
	23 °C	$\pm$ < 0.5 K
	15...35 °C	$\pm$ 0.6 K
	-35...+70 °C	$\pm$ 0.8 K
	Time constant	8.5 min. (according to airflow and wall coupling)
	Output signal, linear (terminal U2)	DC 0...10 V $\hat{=}$ 0...50/-35...+35/-40...+70 °C max. $\pm$ 1 mA
	Output signal, linear (terminal I2) Burden	4...20 mA $\hat{=}$ 0...50/-35...+35/-40...+70 °C refer to "Function"

5/7

Degree of protection	Housing degree of protection to	IEC 60 529
	Base unit	IP65
	Measuring tip	IP40
	Unit with outdoor mounting kit	IP65
Electrical connections	Safety class	III to EN 60 730
	Screw terminals	1 × 2.5 mm <sup>2</sup> or 2 × 1.5 mm <sup>2</sup>
	Cable entry gland (enclosed)	M 16 x 1.5
Environmental conditions	Operation to	
	Climatic conditions	Class 4K2 to IEC 60 721-3-4
	Temperature (housing with electronics)	-40...+70 °C
	LCD-display readable	-25...+70 °C
	Humidity	0...100 % r.h. (with condensation)
	Mechanical conditions	Class 3M2 to IEC 60 721-3-3
	Transport to	IEC 60 721-3-2
	Climatic condition	Class 2K3
	Temperature	-40...+70 °C
	Humidity	<95 % r.h.
Mechanical conditions	class 2M2	
Materials and color	Base	polycarbonate, RAL 7001 (silver-grey)
	Housing cover	polycarbonate, RAL 7035 (light-grey)
	Measuring tip	polycarbonate, RAL 7001 (silver-grey)
	Filter cap	polycarbonate, RAL 7001 (silver-grey)
	Mounting bracket	PA, RAL 7035 (light-grey)
	Sensor (entirely)	silicon-free
	Packaging	corrugated cardboard
	Standards and directives	Product standard
	Electromagnetic compatibility	Immunity EN 61 000-6-1 Emissions EN 61 000-6-3
	CE conformity to	EMC directive 2004/108/EC
	C-tick conformity (EMC) to	EN 61 000-6-3
	UL-conformity	UL 873
Environmental compatibility	Environmental product declaration CE1E1858en provides ISO 14001 (environment) information on environmentally compatible product design ISO 9001 (quality) and assessment (RoHS compliance, composition of sub- stances, packaging, environmental benefit, disposal).	SN 36350 (environmental comp. products) RL 2002/95/EC (RoHS)
Weight	Incl. packaging	
	Without LCD-display	0.152 kg
	With LCD-display	0.175 kg
	AQF3150	0.050 kg
	AQF3153	0.066 kg

## Connection terminals

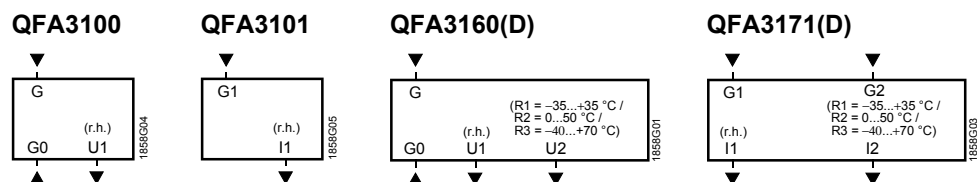

- G, G0    Operating voltage AC 24 V (SELV) or DC 13.5...35 V  
G1, G2    Operating voltage DC 13.5...35 V  
U1        Signal output DC 0...10 V for relative humidity 0...100 %  
U2        Signal output DC 0...10 V for temperature range 0...50 °C (R2 = factory setting)  
          -35...+35 °C (R1) or -40...+70 °C (R3)  
I1        Signal output 4...20 mA for relative humidity 0...100 %  
I2        Signal output 4...20 mA for temperature range 0...50 °C (R2 = factory setting)  
          -35...+35 °C (R1) or -40...+70 °C (R3)

### Note on connection terminals of the QFA3171(D):

Terminals G1(+) and I1(-) for the humidity output must always be connected to power, even if only the temperature output G2(+) and I2(-) is used!

**Dimensions** (all dimensions in mm)

**QFA31...(D)**

Dimensioning without  
(with) LCD-display

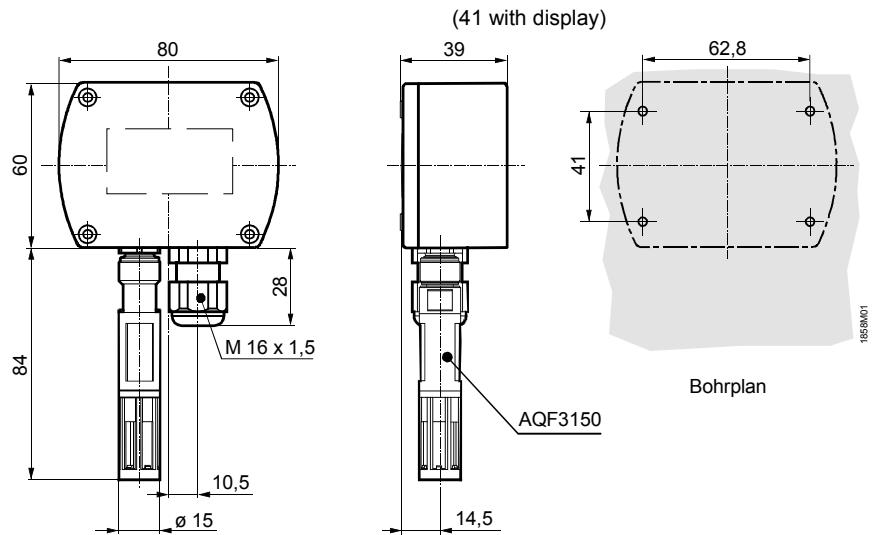

**QFA31... with AQF3100**

