

## FEATURES

- ▶ Mixing valves are suitable for long-lasting operation because of special construction of bearings on axis.
- ▶ Small rotation torque of the valve allow motor actuator operation and in the same time reduce possibility of valve blocking .
- ▶ Compact housing construction does not allow any damages during mounting and also make possible quick and easy mounting of actuator.
- ▶ Valves are specially suitable for upgrading with actuators EUROMIX.
- ▶ Change first O-ring without discharging hydronic system.

**FIRŠT-ROTOTEHNIKA, s.p.**,  
 Radegunda 54, SI-3330 Mozirje, Slovenia  
 tel: +386 3 898 35 00, fax: +386 3 898 35 35  
 e-mail: info@first.si, http://first.si

# FIRST®

## BRASS MIXING VALVES ROTOMIX

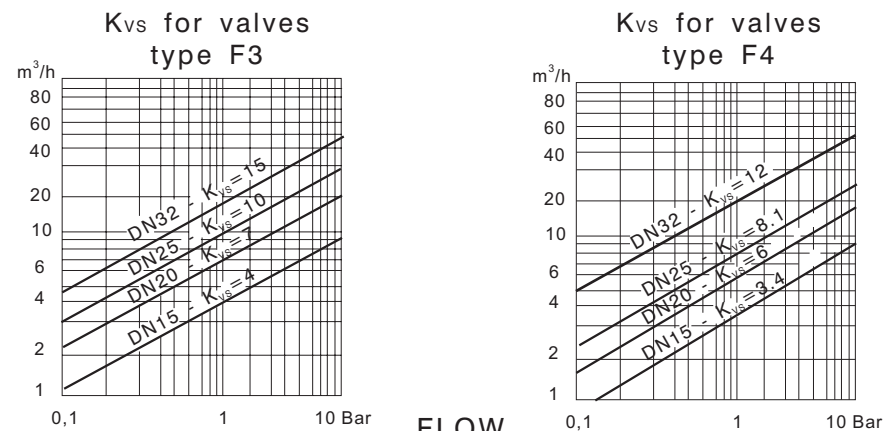

FLOW CHARACTERISTICS

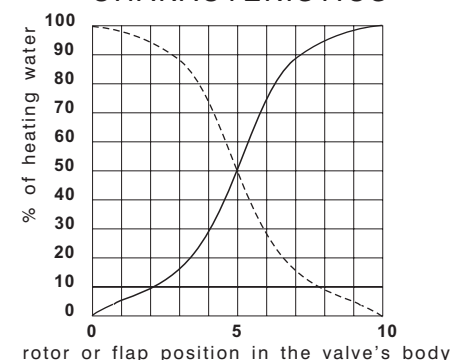

## MIXING VALVE'S PARTS

ROTOMIX F3

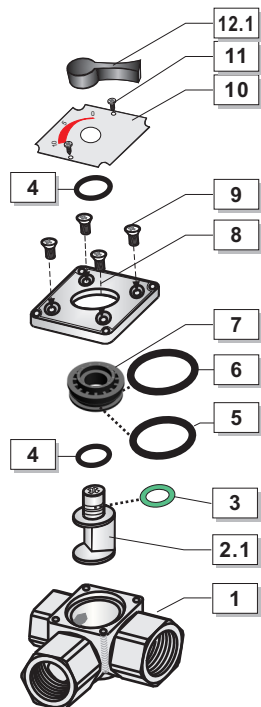

ROTOMIX F4

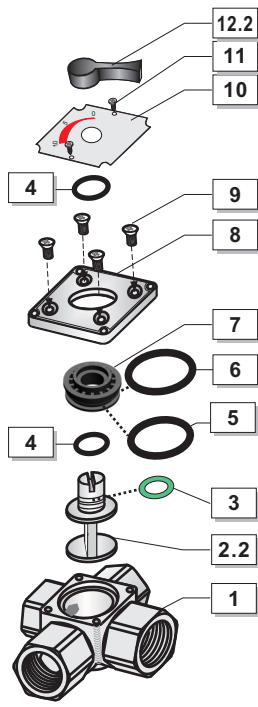

POS	NAME	PCS
1	Body Hot stamped CuZn39Pb3	1
2.1	Rotor with stem Brass CuZn39Pb3	1
2.2	Flap stem Brass CuZn39Pb3	1
3	O-seal 8.73x1,78 Viton FKM	1
4	O-ring 11.6x2.4 EPDM	2
5	O-ring 23.3x2.4 EPDM	1
6	O-ring 27x2.5 EPDM	1
7	Insert RYTON R-4-200 BL	1
8	Valves top alloy	1
9	Screw M5x10 DIN 965	4
10	Position plate Al	1
11	Screw 2.9x6.5 DIN 7981 BC	2
12.1	Handle of 3-way valve PA	1
12.2	Handle of 4-way valve PA	1

Spare O-Ring  
 (Position 4)  
 code: 500075

### Technical data:

Max. medium temperature .....110°C  
 Max. medium pressure .....6 bar  
 Rotation angle .....90°  
 Torque .....0.5 Nm  
 Housing .....stamped brass  
 Rotor .....brass  
 Bearing .....4x O-ring, EPDM  
 To be used with actuators .....MV120..EUROMIX

Mixing valves are used for controlling flow temperature in heating systems in which a certain leakage can be accepted and in which a defined control characteristic is not required.

## ROTOMIX F3

Gap on stem shown rotor's position in the valve's body

CODE	DN	A	B	C	D	E	K <sub>vs</sub>	kg	
41000	½"	15	½"	72	18.5	64	54	4	0.65
41001	¾"	20	¾"	72	18.5	64	54	7	0.55
41002	1"	25	1"	90	24	64	69	10	0.67
41003	1¼"	32	1¼"	90	24	64	69	15	0.89

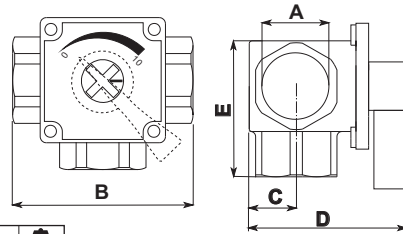

## ROTOMIX F4

Gap on stem shown rotor's position in the valve's body

KODA	DN	A	B	C	D	K <sub>vs</sub>	kg	
41008	½"	15	½"	72	18.5	3.4	0.70	
41009	¾"	20	¾"	72	18.5	6	0.58	
41010	1"	25	1"	90	24	64	8.1	1.33
41011	1¼"	32	1¼"	90	24	64	0.92	

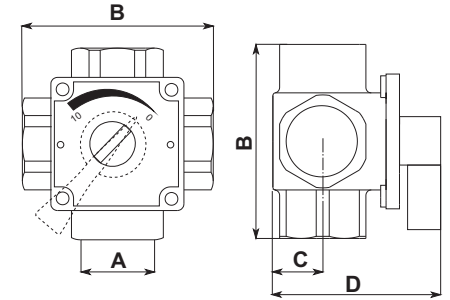

P<sub>MAX</sub> = 6 bar  
T<sub>MAX</sub> = 110°C

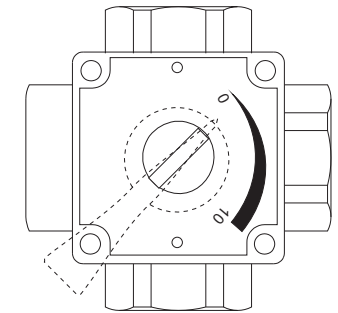
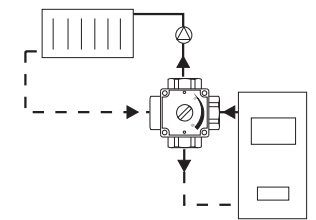
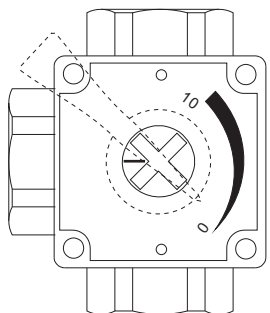
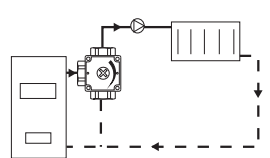
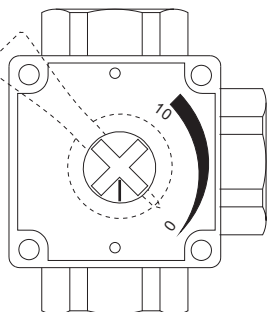
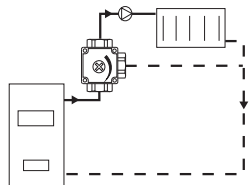
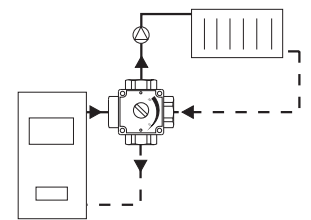
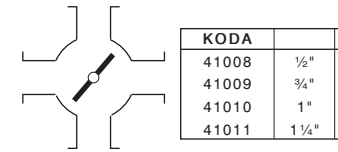
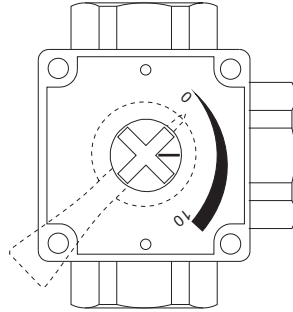
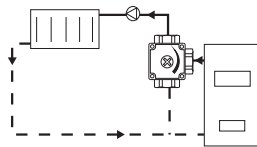
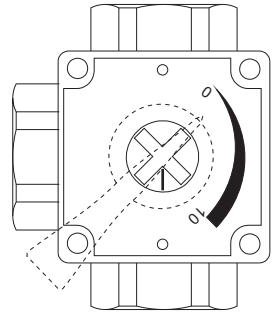
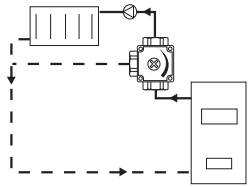

ALL MIXING VALVES ARE COMPATIBLE WITH FIRŠT ACTUATOR

**! WARNING !**

By installation must be observed to according to relevant local standards. The installation must be grounded.