

# Honeywell



## TheraPro HR90

Electronic  
Radiator Controller

### 1. Scope of delivery

The radiator controller packaging contains:

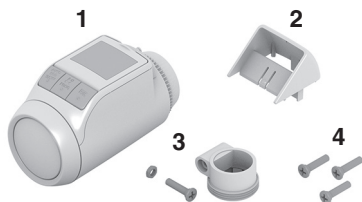

- 1 Radiator controller with valve baseplate M30 x 1.5; batteries included
- 2 Display support
- 3 Valve adapter type Danfoss RA
- 4 Screws for securing radiator controller and battery compartment



**WARNING**

#### Danger of suffocation!

- ▶ Keep packaging materials away from children.

### 2. Brief description

With the electronic radiator controller, you can set your room temperature exactly to your requirements while additionally saving energy.

Please note: The HR90 radiator controller does not directly switch your boiler on/off. It provides local room temperature control whilst the boiler is running. The boiler will be switched on/off by other controls such as timer, thermostat, etc.

#### User-friendly

- Large, adjustable display with backlight.
- Convenient programming by removing the radiator controller from the valve.
- Copy function for transferring the time program to other HR90 radiator controllers.

#### Installation

- The radiator controller fits on the most common radiator valves of the type M30 x 1.5.
- After mounting the radiator controller operates immediately to the factory set program.

#### Features for your convenience

- Individual programs for each day of the week.
- Up to 6 setpoints per day and 3 different temperatures.
- Holiday, party and special day operating modes can be set easily.
- Parameters can be set individually, see Section 9.
- Operation lock/child-proofing to protect against unauthorized operation.
- Optional connection to external sensors and window position contact

#### Energy saving features

- With the window function, the radiator valve is closed when ventilating the room.
- In ECO mode, the room temperature is lowered by 3 °C.
- Optimized control of the room temperature.



**CAUTION**

#### Care of use is required!

- ▶ Use the radiator controller only in accordance with these operating instructions.
- ▶ Do not let children play with the radiator controller.

### 3. Device overview

#### Operating elements and display



- 1 Heating period/setback period in hours
- 2 Day of the week 1 ... 7 (Monday ... Sunday).  
Displayed only while the time program is being programmed
- 3 Temperature display: e.g. set point temperature (factory setting) or measured temperature, if configured in Parameter 9
- 4 Text display with 9 characters
- 5 Button **OK**: Confirm settings
- 6 Button **PROG**: Select the operating modes, set the time program;  
Press button >10 seconds): access to the parameter menu;  
**Programming**: Back to next level up
- 7 Adjustment dial: Change the set point, navigate menu
- 8 Button **AUTO/ECO/MANU**: Change between automatic, ECO and manual mode  
In programming mode: Exit (without storing)
- 9 Battery status
- 10 Operation lock
- 11 Symbol for Comfort temperature 1 ☀, Comfort temperature 2 ☀, Setback temperature ☾

#### Battery display

Battery status	Meaning
	Batteries fully charged
	Batteries half charged
	Batteries have to be replaced soon
	Flashing display: Batteries are dead and have to be replaced

### 4. Installation

Ready to operate in three steps:

- Insert batteries
- Set the language, time and date
- Mount on radiator – FINISHED

#### Inserting/changing batteries

The radiator controller is set for the following battery type:

- 2 alkaline cells 1.5 V; type LR6, AA, AM3
- You can instead use the following batteries or accumulator cells:
  - Lithium 1.5 V; type LR6, AA, AM3
  - NiMH 1.2 V; type LR6, AA, AM3

- i**
- If lithium or NiMH batteries are used, Parameter 14 has to be adapted, see Section 9.
  - Always change batteries in pairs.

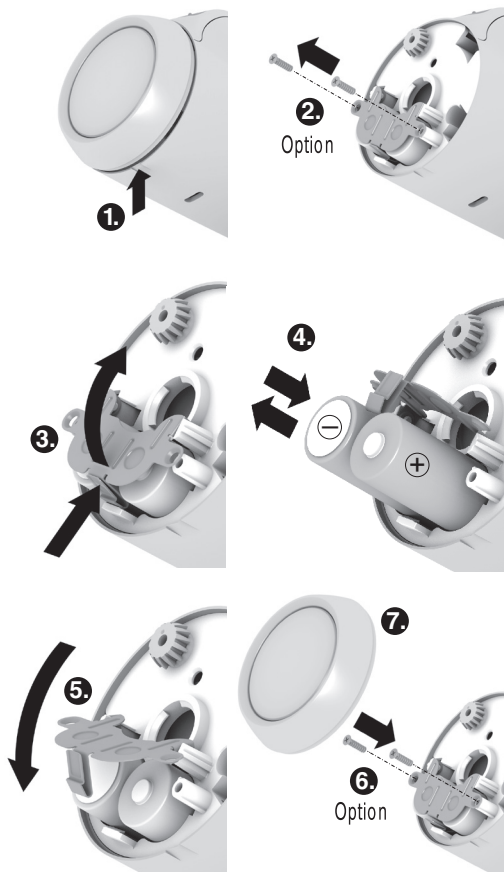

1. Pull off the adjustment dial. To do so, start at the notch on the bottom of the device.
2. If used, unscrew any fastening screws from the battery compartment.
3. Release the lock and fold out battery spring.  
*The battery compartment is now accessible.*
4. Insert the batteries.  
Ensure that the polarity “+” and “-” is correct.
5. Fold down the battery spring and latch it in.
6. Option: Screw the battery spring to secure the batteries against removal.
7. Place the adjustment dial back on.

*First the software version number and then the language DEUTSCH (German) is displayed.*

8. If desired, use the adjustment dial to select a different language.
9. Confirm the selected language with the **OK** button.  
 *HOUR is displayed.*

**i** The language selection is only displayed during initial commissioning. During future battery changes, setting of time and date is prompted directly.

**i** The battery life of new alkaline cells amounts to approx. 2 years. The batteries need changing when the symbol  flashes. All settings are retained when the batteries are changed.



**WARNING**

#### Explosion hazard!

- ▶ Never charge non rechargeable batteries.
- ▶ Never short-circuit batteries or throw them into fire.
- ▶ Dispose of used batteries ecologically.

## Setting the time and date

1. When  *HOUR* is displayed, use the adjustment dial to set the current hour and confirm with **OK**.  
 *MINUTE is displayed.*
2. Use the adjustment dial to set the current minute and confirm with **OK**.  
 *YEAR is displayed.*
3. Use the adjustment dial to set the current year and confirm with **OK**.  
 *MONTH is displayed.*
4. Use the adjustment dial to set the current month and confirm with **OK**.  
 *DAY is displayed.*

5. Use the adjustment dial to set the current day and confirm with **OK**.

*The normal display with set temperature and selected operating mode is displayed.*

## Checking/changing the time and date

Proceed as follows to check or to change the date and time later on:

1. Press the **PROG** button.
2. Select  *TIME DATE* and confirm with **OK**.  
 *HOUR is displayed.*
3. Further checking/changing is carried out as described above.

## Mounting the radiator controller

The radiator controller can be mounted on all common thermostatic valves with an M30 x 1.5 connection without draining system.



**WARNING**

#### Prevent damage to the radiator controller through humidity and moisture!

- ▶ Mount the radiator controller in dry, closed rooms only.
- ▶ Protect the radiator controller against humidity, moisture, dust, direct sunlight or exposure to excessive heat.

## Removing the old thermostat head

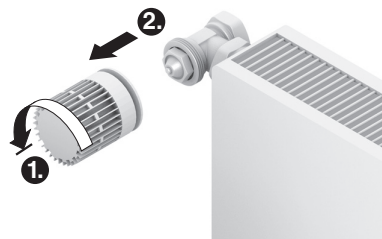

1. Turn the old thermostat head counter-clockwise until it stops and loosen the mounting ring.
2. Remove the old thermostat head from the radiator valve.

## Selecting the adapter

The radiator controller fits on common radiator valves of the type M30 x 1.5. Adapters are required for some valve types.

1. Check whether an adapter is required and, if necessary, select the appropriate adapter.

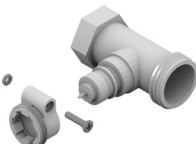
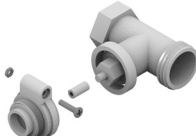
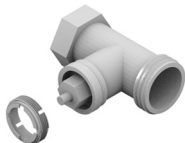
Brand	Illustration	Adapter
Honeywell-Braukmann, MNG, Heimeier, Oventrop valves M30 x 1.5		Not required
Danfoss RA		Supplied
Danfoss RAV		
Danfoss RAVL		

2. Slide the adapter onto the radiator valve and turn it until you feel it click into place.
3. If necessary, screw the adapter tight with a screw.

## Mounting the valve baseplate

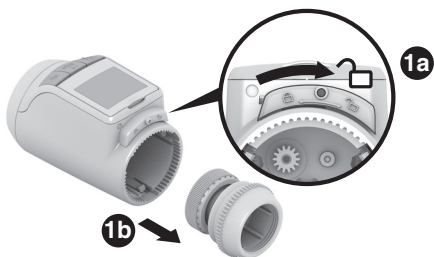

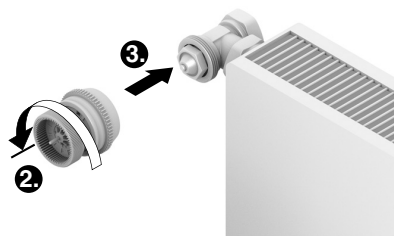

1. Separate the valve baseplate from the radiator controller. To do so, push the slide towards .

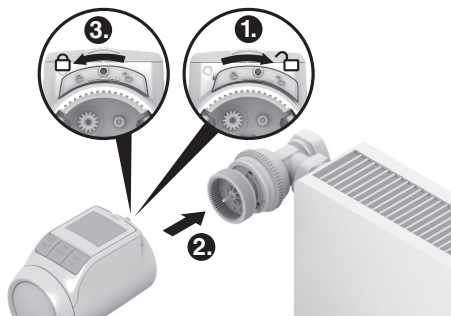

2. Turn the adjustment dial of the valve baseplate counter-clockwise until it stops.
3. Put the valve baseplate onto the radiator valve or the adapter and tighten by hand (without tools!).

## Mounting the radiator controller



1. Ensure that the slide on the radiator controller is in the open position.
2. Put the radiator controller onto the valve baseplate so that the indentation latches in and is no longer visible.
3. Lock the radiator controller in the end position. To do so, push the slide towards .

After approx. 1 minute **CYCL** (self-test) is displayed. Afterwards the radiator controller changes to automatic mode.

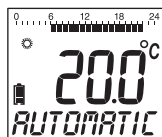

**i** The radiator controller only operates if it is locked correctly in the end position.

**FINISHED!** – After mounting, the radiator controller operates immediately in the factory setting (standard time program), see Section 5.

## Securing the radiator controller

- i** The radiator controller and the batteries can be secured against removal by using the supplied screws.

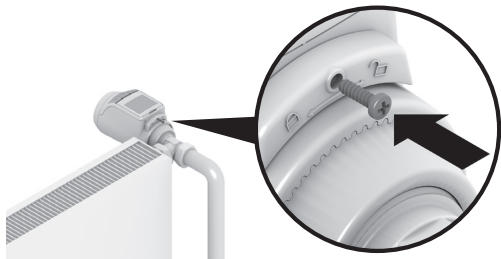

## Setting the position of the display

In order to improve the legibility the display of the radiator controller can be tilted to different positions (10°, 20°, 30°, 40°).

The angle of 40° can be fixed with the supplied display support.

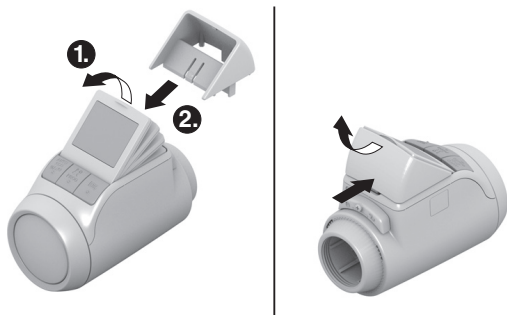

## Mounting

1. Lift the display and set it to the desired angle.
2. If desired, tilt the display by 40° and slide the display support from above between the display and the housing until it latches in.

## Unmounting

- Press the display support in at the back and remove it upwards.

## Connecting optional sensors and window contact

The following external sensors and window contacts can be connected to the HR90 radiator controller:

- HCW23 setpoint adjuster
- RF20 room sensor
- HCA30 floating window contact

- i** The ACS90 cable is required to connect external sensors and the window contact.
- Micro B mini-plug / open ends
  - 2 m long
  - Not included in the scope of delivery

## Operation with HCW23 setpoint adjuster

The room temperature is measured by the HCW23 setpoint adjuster. The HR90 internal room temperature sensor is not used in this particular application. The adjustment dial of the HCW23 can be used to change the room temperature  $\pm 12$  K as an offset to the temperature set/programmed at the HR90. The offset setting remains valid until it is changed again.

## Operation with RF20 room sensor

The room temperature is measured by the external RF20 room sensor. The HR90 internal room temperature sensor is not used in this particular application.

## Operation with window contact

When the window is opened, the window contact is opened and the radiator valve closes. When the window is closed again, the radiator controller returns to normal operation.

The frost-protection function ensures that the radiator valve opens when the temperature drops below 5 °C.

- i**
- When de-installing a connected room sensor RF20 or room unit HCW23, remove the batteries and insert them again to avoid error messages.
  - When de-installing the window contact, change parameter 17 to 1 or 0, see section 9.

## Cable connection

**i** For further information also refer to the documentation for HCW23, RF20 and HCA30.

► Connect the ACS90 cable as follows to the external sensor and window contact:

### HCW23 setpoint adjuster

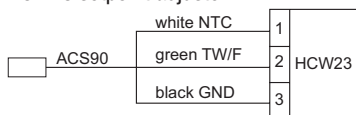

### RF20 room sensor

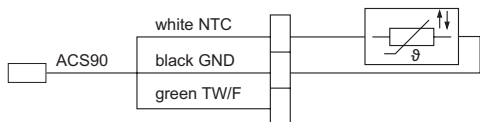

### RF20 room sensor and floating HCA30 window contact



### HCA30 floating window contact

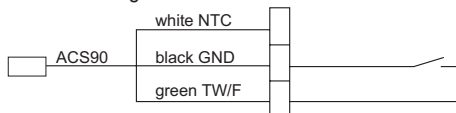

## Connecting the cable with the HR90 radiator controller

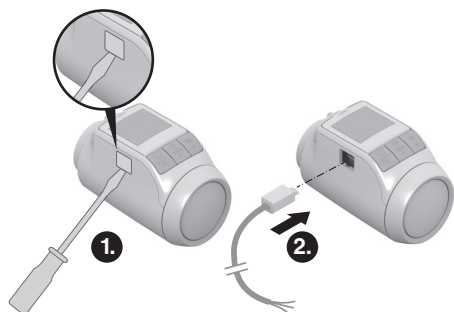

1. Remove the side cover from the radiator controller.
2. Insert the cable ASC90 into the HR90 radiator controller.

*The radiator controller recognizes the connected sensor / window contact automatically.*

## 5. Operation

### Standard time program (factory setting)

In automatic mode, the radiator controller automatically controls the room temperature in accordance with the stored time program.

### Week program 1: At home all day

Factory preset time program is set for each day of the week Mo – Su (1 – 7):

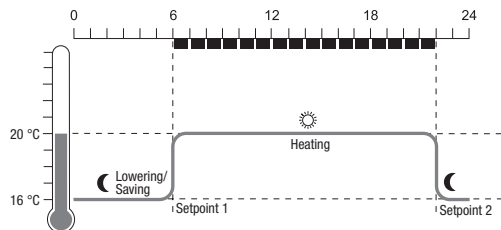

Set-point	Time	Temperature
1	6:00 – 22:00	☀ 20 °C (Comfort temperature 1)
2	22:00 – 6:00	☾ 16 °C (Setback temperature)

- i**
- Two further week programs are stored in the radiator controller. Further information is available in Section 9.
  - You can also adapt one of the stored week programs to your individual requirements, see Section 8.

### Adapting the temperature temporarily

If you want to change the temperature specified by the time program temporarily:

- Set your desired temperature using the adjustment dial.

*The change remains in effect until the next setpoint.*

- i** The process of changing the temperatures permanently is described in Section 7.

## Saving energy in ECO mode

In ECO mode, the room temperature in automatic mode specified by the time program is lowered by 3 °C.

- ▶ To activate ECO mode, press the button **AUTO/ECO/MANU** until *ECONOMY* is displayed.

*The displayed temperature is reduced by 3 °C.*

*ECO mode runs until you press the button **AUTO/ECO/MANU** again and select a different operating mode.*

## Manual mode

In manual mode, the radiator controller operates at the (manually) set temperature until you change the temperature or change to a different operating mode.

- ▶ To activate the manual mode, press the button **AUTO/ECO/MANU** until *MANUAL* is displayed.

*The temperature can be adjusted manually using the adjustment dial.*

*Manual mode runs until you press the button **AUTO/ECO/MANU** again and select a different operating mode.*

## 6. Programming – Operating modes

### Overview of the operating modes

- "Party" operating mode: In this operating mode, you can specify a temperature for a number of hours. After the set period has expired, the radiator controller changes back to automatic mode.
- "Day off" operating mode: If, for example, a public holiday during the week, the automatic mode settings may not meet your requirements on these days. In such cases you can activate a different time program for one or more days. After the set period has expired, the radiator controller changes back to automatic mode.
- "Holiday" operating mode: In this operating mode you can specify a temperature for a specific number of days. After the set period has expired, the radiator controller changes back to automatic mode.

## Selecting operating modes

### Selecting the "Party" or "Holiday" operating mode

1. Press the **PROG** button and turn the adjustment dial to the left until *PARTY* or *HOLIDAY* is displayed.
2. Confirm the selected operating mode with the **OK** button.  
*Hours or Days flashes.*
3. Use the adjustment dial to set the desired number of hours or days and confirm with **OK**.  
*The temperature display flashes.*
4. Use the adjustment dial to set the desired temperature and confirm with **OK**.  
*The selected operating mode and the set temperature are displayed.*

### Selecting the "Day off" operating mode

1. Press the **PROG** button and turn the adjustment dial to the left until *DAY OFF* is displayed.
2. Confirm the selected operating mode with the **OK** button.  
*DRYS flashes.*
3. Use the adjustment dial to set the desired number of days and confirm with **OK**.  
*The selected operating mode is displayed.*

### i

- The procedure of creating the time program for special days is described in Section 8.
- When you enter the number of days for holidays/special day the current day counts as the first day.
- An overview of the program structure is shown on the last page of these instructions.

## 7. Programming – Temperatures

Three preset temperatures can be assigned to the set points in the time program:

- Comfort temperature 1  Factory setting 20 °C
- Comfort temperature 2  Factory setting 22 °C
- Setback temperature  Factory setting 16 °C

### Setting the temperatures

1. Press the **PROG** button.  
*COMFORT 1* is displayed.
2. Press the **OK** button, use the adjustment dial to set the Comfort temperature 1 and confirm with **OK**.  
*SAVED* is displayed briefly and then again *COMFORT 1*.
3. Turn the adjustment dial clockwise until the next temperature is displayed.
4. Repeat Steps 2 and 3 for the Comfort temperature 2 and the Setback temperature.
5. Use the **AUTO** button to exit programming.

**i** The three preset temperatures (Comfort temperature 1, 2 and Setback temperature) can be changed at any time.

**i**

- During programming the **PROG** button can be used to return to the next level up.
- You can abort programming at any time by using the **AUTO** button.

**i** An overview of the program structure is shown on the last page of these instructions.

## Operating hints

### Operating the radiator controller comfortably

The radiator controller can be removed from the radiator to facilitate programming.

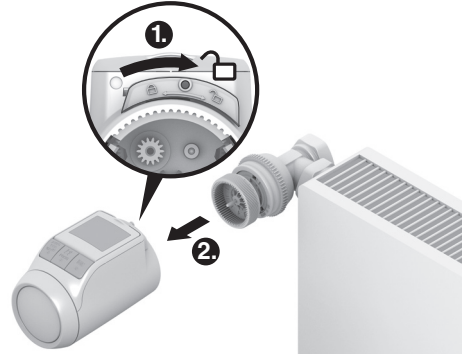

1. Unlock the radiator controller. To do so, push the slide at the radiator controller towards .
2. Pull the radiator controller off the valve baseplate.

### Lost your way in the program?

- Press the button **AUTO/ECO/MANU**

*AUTOMATIC* is displayed. The last entry is rejected.

## 8. Programming – Time program

### Planning the time program

You can specify up to 6 setpoints per day.

The following has to be assigned to each setpoint:

- One of the three preset temperatures (Comfort temperature 1, 2 and Setback temperature).
- Beginning of the Heating/Setback period
- End of the Heating/Setback period

### Example

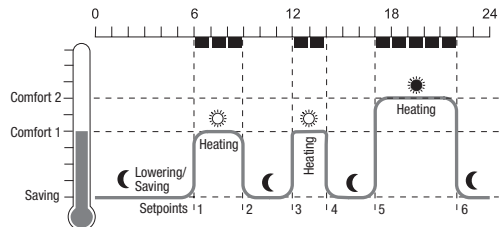



The example shows the following time program:

Set-point	Time	Temperature
1	6:00 – 9:00	☀ 20 °C (Comfort temperature 1)
2	9:00 – 12:00	☾ 16 °C (Setback temperature)
3	12:00 – 14:00	☀ 20 °C (Comfort temperature 1)
4	14:00 – 17:00	☾ 16 °C (Setback temperature)
5	17:00 – 22:00	☀ 22 °C (Comfort temperature 2)
6	22:00 – 6:00	☾ 16 °C (Setback temperature)

**i** An overview of the program structure is shown on the last page of these instructions.

## Week program

You can adjust the time program to your personal weekly routine. You have the following options to this purpose:

- Separate time programs for weekdays Mo – Fr (1 – 5) and weekend Sa – Su (6 – 7)
- One time program for the days of the week Mo – Su (1 – 7)
- A different time program for each day of the week Mo, Tu, We, Th, Fr, Sa, Su (1, 2, 3, 4, 5, 6, 7)

**i** We recommend that you write down your time program before beginning programming.

## Setting the time program

### Selecting weekdays

1. Press the **PROG** button.  
*COMFORT* is displayed.
2. Turn the adjustment dial clockwise until **PROGRAM** is displayed.
3. Press the **OK** button and use the adjustment dial to select the desired weekdays for your time program:  
*MO - FR, SA - SU, MO - SU, MO, TU, ..., SU* or *DRY OFF*
4. Confirm the selected weekdays with the **OK** button.  
*The temperature as well as the beginning and end of the first setpoint, e.g.:*

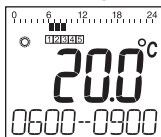

- i**
- The end of a setpoint is also the beginning of the next setpoint.
  - You can use the adjustment dial to change from one setpoint to another and thus view the setting of all the programmed setpoints.
  - Only the programmed setpoints are displayed.

### Editing setpoints

1. In order to edit the displayed setpoint press the **OK** button.

*The temperature display flashes.*

2. Use the adjustment dial to select the desired temperature (Comfort temperature 1, 2 or Setback temperature) for the selected setpoint and confirm with **OK**.

*The beginning of the selected setpoint flashes.*

- i** The time scale for programming of the setpoints begins at 3:00 in the morning and ends at 2:50 on the following day.

3. Use the adjustment dial to set the desired beginning for the selected setpoint and confirm with **OK**.

*The end of the selected setpoint flashes.*

4. Use the adjustment dial to set the desired end of the selected setpoint and confirm with **OK**.

*SAVED* is displayed briefly. Subsequently the temperature as well as the beginning and end of the setpoint are displayed.

5. For the further setpoints also select the temperature as well as the beginning and end of the setpoint as described in Steps 1 to 5.

- i**
- A setpoint is not saved until the temperature, beginning and end have been confirmed with the **OK** button.
  - If a setpoint is not required, select the setting

### Editing further weekdays

1. When all the setpoints have been edited, use the **PROG** button to select the weekdays.
2. Edit the setpoints for the next weekdays.
3. After all the required weekdays have been set, exit programming with the **AUTO** button.

The radiator controller operates immediately in automatic mode with the set time program.

## Deleting a setpoint

- When a setpoint is not required, select the temperature setting **--. --** and confirm with **OK**.

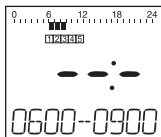

**i** The first setpoint cannot be deleted.

## Adding a setpoint

1. Turn the adjustment dial until **ADD NEW** is displayed and confirm with **OK**.

*The temperature display flashes.*

2. Use the adjustment dial to select the desired temperature (Comfort temperature 1, 2 or Setback temperature) for the new setpoint and confirm with **OK**.

*The beginning of the new setpoint flashes.*

3. Use the adjustment dial to set the desired beginning for the new setpoint and confirm with **OK**.

*The end of the desired setpoint flashes.*

4. Use the adjustment dial to set the desired end of the new setpoint and confirm with **OK**.

**i** **ADD NEW** is only displayed when less than 6 setpoints are programmed.

## Copying the time program

If several HR90 radiator controllers are to operate with the same time program, the time program only has to be created at one device (master) and can then be copied to further radiator controllers.

**i** The ACC90 cable is required to copy the time program.

- 2 x Micro B mini-plugs
- 0.5 m long
- Not included in the scope of delivery

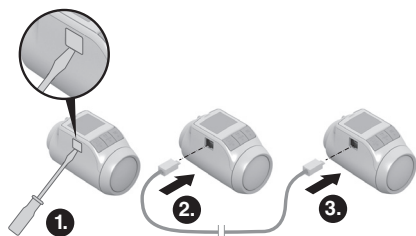

1. Remove the side cover from all the radiator controllers.
2. Connect the master (with time program) and a further HR90 radiator controller using the ACC90 cable.
3. Press the buttons **AUTO** and **OK** at both devices simultaneously for 4 seconds.

*COM MODE is displayed in the display of both devices.*

4. Press the **PROG** button at the master.

*MASTER is displayed on the master and then TRANSMIT.*

*COM MODE is displayed on the other device and then RECEIVE.*

*The time program is copied.*

5. The copying process is completed when **FINISHED** is displayed at both devices.
6. After 2 seconds the device with the copied time program changes to the automatic mode, **COM MODE** is displayed again at the master.
7. Disconnect the ACC90 cable from the device with the copied time program.

**i** If there are no activities at one of the two radiator controllers for 4 minutes, they change automatically to automatic mode.

## Copying to further devices

1. Insert the ACC90 cable into the next device.
2. Press the buttons **AUTO** and **OK** at the next device simultaneously for 4 seconds.

*COM MODE is displayed at this device.*

*COM MODE is displayed at the master.*

3. Press the **PROG** button at the master.

*The further copying procedure is the same as described at the first copying process.*

## Terminating copying

After the last copying process has been completed:

1. Press the **AUTO** button at the master in order to change to the automatic mode.
2. Remove the ACC90 cable and put the side cover back on at all the devices.

## 9. Controller operating parameters

### Overview

If required, the 16 basic settings (parameters) can be adjusted.

Factory settings have a grey background.

Parameters marked with an \* are described in more detail below.

Par.	Setting	Meaning
1		Language setting
	1	German
	2	English
	3	Danish
	4	Swedish
	5	Norwegian
6	Finnish	
2		Preset time programs *
	0	Week program 1 "At home all day"
	1	Week program 2 "Lunch break at home"
	2	Week program 3 "Part-time work"
3		Backlight *
	0	Deactivated
1	Activated	
4		Summer/winter time changeover
	0	No automatic changeover
1	Automatic changeover	
5		Duration of the window function *
	0	Window function not active
	30	Valve opens at the latest after 30 minutes
	...	...
	90	Valve opens at the latest after 90 minutes
6		Sensitivity of the window function during dropping room temperature *
	0.2	0.2 (sensitive)
	...	...
	2.0	2.0 (less sensitive) Factory setting: 0.4
7		Sensitivity of the window function during rising room temperature *
	0.1	0.1 (sensitive)
	...	...
	2.0	2.0 (less sensitive) Factory setting: 0.2
8		Setting the valve stroke *
	0	Standard valve stroke
	1	Full-stroke mode
9		Temperature representation in the display *
	0	Set/programmed temperature (setpoint temperature)
1	Measured room temperature	

Par.	Setting	Meaning
10		Upper temperature limit
	16	The room temperature cannot be set higher than the specified upper temperature limit (Max Limit).
	17	The room temperature cannot be set higher than the specified upper temperature limit (Max Limit).
	...	...
30	Factory setting: 30 °C	
11		Lower temperature limit
	5	The room temperature cannot be set lower than the specified lower temperature limit (Min Limit).
	6	The room temperature cannot be set lower than the specified lower temperature limit (Min Limit).
	...	...
15	Factory setting: 5 °C	
12		Optimization function *
	0	No optimization
	1	Optimum start
2	Optimum start/stop	
13		Temperature offset *
	3	To adjust the temperatures measured by the radiator controller and in the room
	...	...
-3	Factory setting: 0 °C	
14		Battery type
	0	Alkaline
	1	Lithium
2	NiMH (accumulator chargeable)	
15		Display valve position *
	0	No display of the valve position
1	Momentary display of the valve position	
16		Valve exercise day *
	0	Monday
	1	Tuesday
	2	Wednesday
	3	Thursday
	4	Friday
	5	Saturday
	6	Sunday
7	Off	
17		Window open function *
	0	Off (no window function)
	1	Auto (corresponding to Parameters 5-7)
2	Cabled (with floating window contact)	
18		Temperature unit
	0	°Celsius
1	°Fahrenheit	
19		Restore to factory setting
	0	No reset
	1	Reset only the basic settings
	2	Reset only the time program
3	Reset all	

## Changing parameters

1. Keep the **PROG** button pressed for at least 10 seconds until Parameter 1 flashes (left-hand digit).

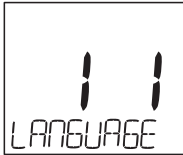

The right-hand digit shows the current setting.  
The parameter is displayed additionally in plain text.  
For example, the display *! !* stands for Parameter 1 (language) with Setting 1 (German).

2. Use the adjustment dial to select the desired parameter (left-hand digit).
3. Press the **OK** button to edit the parameter.  
*The current setting of the parameter flashes (right hand digit).*
4. Use the adjustment dial to set the desired setting (right-hand digit) and confirm with **OK**.  
*The parameter being edited flashes (left-hand digit).*
5. For the further parameters repeat Steps 2 to 4.
6. Use the **AUTO** button to return to automatic mode.

## Description of the parameters

### Parameter 2 –

#### Selecting the preset time programs

- **Week program 1** (factory setting, 2 setpoints):  
Mo – Su (1 – 7) at home all day  
This time program is described in Section 8.
- **Week program 2** (6 setpoints):  
Mo – Fr (1 – 5) lunch break at home  
Sa – Su (6 – 7) like Week program 1

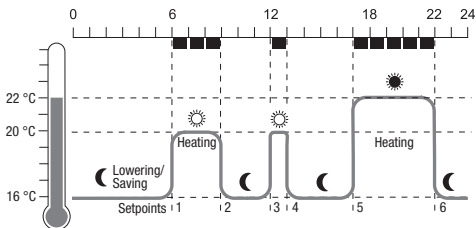

Set-point	Time	Temperature
1	6:00 – 9:00	☀ 20 °C (Comfort temperature 1)
2	9:00 – 12:00	☾ 16 °C (Setback temperature)
3	12:00 – 13:00	☀ 20 °C (Comfort temperature 1)
4	13:00 – 17:00	☾ 16 °C (Setback temperature)
5	17:00 – 22:00	☀ 22 °C (Comfort temperature 2)
6	22:00 – 6:00	☾ 16 °C (Setback temperature)

- **Week program 3** (4 setpoints):  
Mo – Fr (1 – 5) part-time work  
Sa – Su (6 – 7) like Week program 1

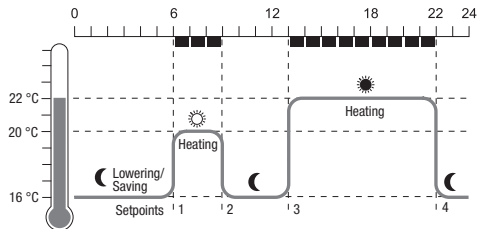

Set-point	Time	Temperature
1.	6:00 to 9:00	☀ 20 °C (Comfort temperature 1)
2.	9:00 to 13:00	☾ 16 °C (Setback temperature)
3.	13:00 to 22:00	☀ 22 °C (Comfort temperature 2)
4.	22:00 to 6:00	☾ 16 °C (Setback temperature)

### Parameter 3 – Backlight

The display has a backlight for reading the information.

- The backlight is ON when the adjustment dial is turned or a button is pressed.
- The backlight switches OFF if no action is carried out at the radiator controller for approx. 7 seconds in order to save battery power.

## Parameters 5 to 7 – Window function

In order to save energy, the radiator controller closes the radiator valve when you open a window resulting in a large drop of the temperature.

When you close the window so that the temperature rises the radiator controller opens the radiator valve again.

If you should ever forget to close the window, the radiator controller opens automatically after the set time in order to ensure frost protection.

## Parameter 8 – Valve stroke

The radiator controller operates with the optimum valve stroke set in the factory.

If the entire valve stroke is to be used or if the valve does not open completely, activate the full-stroke mode.

## Parameter 9 – Temperature representation in the display

- In the factory setting the set or programmed temperature (Comfort temperature 1, 2 or the Setback temperature) is displayed.
- With the setting "measured temperature" the measured room temperature is displayed. A changeover to the set temperature is carried out by turning the adjustment dial or pressing a button. If required, the temperature can now be reset. The display returns to the measured temperature after approx. 3 seconds. Due to the heat influence of the radiator the "measured temperature" displayed at the radiator controller can differ from the temperature measured at another point in the room.

## Parameter 12 – Optimization function

**Without optimization** (factory setting) the radiator controller begins to heat up the room or lower the temperature at the programmed time.

For example, in order to have a warm bathroom at 7:00, the setpoint has to be brought forward. Otherwise the room only starts heating at 7:00. However, the advanced setpoint may lie too early so that heating is started far earlier than necessary.

**With optimization** the radiator controller calculates when to open the valve in order to achieve the desired temperature at the set time.

- **Optimum start**  
The room is heated up at the optimum moment in order to reach the programmed temperature.
- **Optimum start/stop:**  
The room is heated up at the optimum moment and cooled down at an earlier moment.

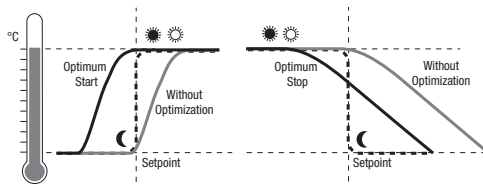

## Parameter 13 – Temperature offset

Since the radiator controller measures the room temperature in the area of the radiator, it is possible that this temperature deviates from the temperature measured at a different point in the room.

If, for example, 20 °C is measured in the room and 21.5 °C at the radiator, this effect can be compensated by an offset of -1.5 °C.

## Parameter 15 – Display of the valve position

When this parameter is activated (setting "1"), the calculated valve position (0 to 100% opened) is displayed momentarily.

The main display is shown again after approx. 3 minutes or when the **AUTO** button is pressed.

## Parameter 16 – Valve exercise day

If the radiator valve has not been opened once completely within the period of 2 weeks, a self-test (forced operation) is carried out. The radiator controller opens the radiator valve briefly on the subsequent Monday (factory setting) in order to prevent seizing. The weekday for valve protection can be selected freely.

## Parameter 17 – Window open function

- If a window contact is connected, the parameter is set automatically to "2" (cabled). The window function is controlled by the window contact.
- If no window contact is present, the parameter must be set to "0" or "1".

## 10. Further functions

### Monitoring functions

#### Window function

If you open a window causing the temperature to drop, the radiator controller closes the radiator valve in order to save energy.

*WINDOW* is displayed.

When the temperature rises again, but at the latest after the set period (factory setting: 30 minutes), the radiator controller opens the radiator valve again.

You can also open the radiator valve beforehand by pressing the **AUTO** button or turning the adjustment dial.

The sensitivity of the radiator controller to a temperature drop or temperature rise can be set, see Section 9, Parameters 5 to 7.

If a window contact is connected, the window function reacts directly to the opening and closing of the window, see Parameter 17.

#### Valve protection

If the radiator valve has not been opened once completely within a period of 2 weeks, a self-test (forced operation) is carried out. The radiator controller opens the radiator valve briefly on the subsequent Monday (factory setting) in order to prevent seizing.

*CYCL* is displayed.

The day for the valve protection can be set in Parameter 16.

#### Frost protection

If the temperature drops below 5 °C, the radiator controller opens the radiator valve until the temperature rises above 6 °C again. This prevents the heating system from freezing up.

*FROST* is displayed.



The heating must be switched on to ensure the frost protection function.

### Manual override

If you have switched off the central heating system in summer and do not want to waste the batteries of the radiator controller, you can close the radiator valve continuously.

#### Closing the valve

1. Press the button **AUTO/ECO/MANU** until *MANUAL* is displayed.
2. Turn the adjustment dial counter-clockwise until *OFF* is displayed.

*The radiator valve now remains closed. The valve and frost protection functions continue to be active.*

#### Opening the valve

- ▶ Use the **AUTO/ECO/MANU** button to change to automatic mode.
- or –
- ▶ Set the desired temperature in manual operation.

### Child-proofing / Operation lock

You can block the radiator controller to protect it against unauthorized operation:

- ▶ Keep the **AUTO/ECO/MANU** and **PROG** buttons pressed simultaneously for at least 3 seconds.



*The symbol  is displayed.*



The same key combination is used to release the radiator controller again for operation.

## 11. Help with problems

### Error table

Problem/Display	Cause	Remedy
 flashes	Batteries flat	Replace the batteries.
<b>E1</b> <b>SENSOR</b>	Device defective	Replace the device.
<b>E2</b> <b>VALVE</b>	Motor can not be moved.	Check the installation.
The radiator stays hot	The radiator valve does not close fully.	Check the installation. If appropriate, change to full-stroke mode (Parameter 8).
The room does not heat up during optimization	Heating is not switched on in time	Ensure that the pre-controller switches on the heating. Synchronize the on/off times of boiler control and radiator controller.
Motor does not move	Valve baseplate not interlocked	Set the slider to the position  .

### Emergency operation when batteries are flat

1. Unlock the radiator controller. To do so, push the slide at the radiator controller towards .
2. Pull the radiator controller off the valve baseplate.
3. Operate the radiator valve by hand using the adjustment dial on the valve baseplate.

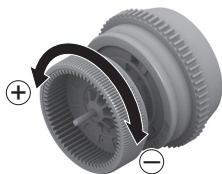

### Restoring the factory setting

1. Keep the **PROG** button pressed for approximately 10 seconds until Parameter 1 flashes (left-hand digit).
2. Use the adjustment dial to select Parameter 19 (left-hand digit) and Setting 1 (right-hand digit).
3. Press the **OK** button to restore the factory setting.

## 12. Technical data

Type	HR90
Protection class	IP30
Supply voltage	Battery type LR6, AA, AM3 Alkaline: 2 x 1.5 V Lithium: 2 x 1.5 V NiMH: 2 x 1.2 V
Connection to the radiator	M30 x 1.5
Ambient temperature	0 ... 50 °C
Dimensions	96 x 54 x 60 mm
Ambient conditions	For living area, business and trade sections as well as small businesses
Humidity	10 ... 90 % rel. humidity

## 13. Disposal

The radiator controller has to be disposed of in accordance with WEEE directive 2002/96/EC – Waste Electrical and Electronic Equipment directive.



- ▶ Dispose of the packaging and product in a corresponding recycling center.
- ▶ Do not dispose of the unit with the domestic refuse.
- ▶ Do not burn the product.

# 14. Programming – Overview

## Temperatures and operating modes

(turn adjustment dial counter-clockwise) ↺

Button **PROG**

↻ (turn adjustment dial clockwise)

<i>TIME DATE</i>	<i>HOLIDAY</i>	<i>DRY OFF</i>	<i>PARTY</i>	<i>COMFORT 1</i>	<i>COMFORT 2</i>	<i>SETBACK</i>	<i>PROGRAM</i>
OK	OK	OK	OK	OK	OK	OK	OK
↺ Hours	↺ Days	↺ Days	↺ Hours	↺ Temp.	↺ Temp.	↺ Temp.	Edit time program, see below
OK	OK	OK	OK	OK	OK	OK	
↺ Minute	↺ Temp.		↺ Temp.				
OK	OK		OK				
↺ Year							
OK							
↺ Month							
OK							
↺ Day							
OK							

## Time program

<i>PROGRAM</i>
OK

↺ (turn adjustment dial)

<i>MO - FR</i>	<i>SA - SU</i>	<i>MO - SU</i>	<i>MO</i>	<i>TU</i>	<i>...</i>	<i>SU</i>	<i>DRY OFF</i>
OK	OK	OK	OK	OK	OK	OK	OK

↺ (turn adjustment dial)

SP 1	...	SP 6	New setpoint:	<i>ADD NEW</i>	Delete a setpoint:	SP x
OK	OK	OK	OK	OK	OK	OK
↺ Temp.	↺ Temp.	↺ Temp.	↺ Temp.	↺ Temp.	↺ --- --	(Delete)
OK	OK	OK	OK	OK	OK	
↺ Beginning	↺ Beginning	↺ Beginning	↺ Beginning	↺ Beginning		
OK	OK	OK	OK	OK		
↺ End	↺ End	↺ End	↺ End	↺ End		
OK	OK	OK	OK	OK		

Manufactured for and on behalf of the Environmental and Combustion Controls Division of Honeywell Technologies Sàrl, Rolle, Z. A. La Pièce 16, Switzerland by its Authorized Representative

Honeywell  
Honeywell House  
Skimped Hill Lane  
Bracknell  
Berkshire RG12 1EB  
United Kingdom

The right is reserved to make modifications that serve improvement.



50080331-001B

