



## 2-Port Seat Valves with Flange, PN 16

VVF40...

- Grey cast iron EN-GJL-250 valve body
- DN 15...150
- $k_{vs}$  1.9...315 m<sup>3</sup>/h
- Can be equipped with SQX... electromotoric or SKD...-, SKB...- and SKC...- electrohydraulic actuators

### Use

For use in heating, ventilating, and air conditioning systems as a control or safety shutoff valve.

For closed circuits only (mind cavitation, refer to page 6).

## Type summary

Type	DN	$k_{vs}$ [m <sup>3</sup> / h]	$S_v$	
VVF40.15-1.9	15	1,9	> 50	
VVF40.15-2.5		2,5		
VVF40.15-3		3		
VVF40.15-4		4		
VVF40.25-5	25	5		
VVF40.25-6.3		6,3		
VVF40.25-7.5		7,5		
VVF40.25-10		10		
VVF40.40-12	40	12		> 100
VVF40.40-16		16		
VVF40.40-19		19		
VVF40.40-25		25		
VVF40.50-31	50	31		
VVF40.50-40		40		
VVF40.65-49	65	49		
VVF40.65-63		63		
VVF40.80-78	80	78		
VVF40.80-100		100		
VVF40.100-124	100	124		
VVF40.100-160		160		
VVF40.125-200	125	200		
VVF40.125-250		250		
VVF40.150-300	150	300		
VVF40.150-315		315		

DN = Nominal size

$k_{vs}$  = Nominal flow rate of cold water (5...30 °C) through the fully open valve ( $H_{100}$ ) by a differential pressure of 100 kPa (1 bar)

$S_v$  = Rangeability  $k_{vs} / k_{vr}$

$k_{vr}$  = Smallest  $k_v$  value, at which the flow characteristic tolerances can still be maintained, by a differential pressure of 100 kPa (1 bar)

### Accessories

Type	Description
ASZ6.5	Electric stem heating element, AC 24 V / 30 W, required for media below 0 °C

### Order

When ordering please give quantity, product name and type reference.

Example: 2 two-port valves VVF40.50-31

### Delivery

Valves, actuators and accessories are packed and supplied separately.  
The valves are supplied without counter-flanges and without flange gaskets.

### Spare parts

See overview, section „Spare parts“, page 10

## Equipment combinations

Valves	Actuators									
	H <sub>100</sub> [mm]	SQX... <sup>1)</sup>		SKD... <sup>1)</sup>		SKB...		SKC...		
		$\Delta p_{max}$	$\Delta p_s$	$\Delta p_{max}$	$\Delta p_s$	$\Delta p_{max}$	$\Delta p_s$	$\Delta p_{max}$	$\Delta p_s$	
[kPa]										
VVF40.15-1.9	20	300	1600	300	1600	300	1600			
VVF40.15-2.5										
VVF40.15-3										
VVF40.15-4										
VVF40.25-5										
VVF40.25-6.3										
VVF40.25-7.5										
VVF40.25-10										
VVF40.40-12										
VVF40.40-16										
VVF40.40-19										
VVF40.40-25										
VVF40.50-31										
VVF40.50-40										
VVF40.65-49										
VVF40.65-63										
VVF40.80-78										
VVF40.80-100										
VVF40.100-124	40								200	300
VVF40.100-160										
VVF40.125-200										
VVF40.125-250										
VVF40.150-300										
VVF40.150-315										

<sup>1)</sup> Usable up to maximum medium temperature of 150 °C

H<sub>100</sub> = Nominal stroke

$\Delta p_{max}$  = Maximum permissible differential pressure across valve's control path, valid for the entire actuating range of the motorized valve

$\Delta p_s$  = Maximum permissible differential pressure at which the motorised valve will close securely against the pressure (close off pressure)

## Actuator overview

Type	Actuator type	Operating voltage	Positioning signal	Spring return	Positioning time	Positioning force	Data sheet
<b>SQX32.00</b>	Electro-motoric	AC 230 V	3-position	No	150 s	700 N	N4554
<b>SQX32.03</b>					35 s		
<b>SQX82.00</b>		AC 24 V			150 s		
<b>SQX82.03</b>					35 s		
<b>SQX62</b>					DC 0...10 V <sup>1)</sup>		
<b>SKD32.50</b>	Electro-hydraulic	AC 230 V	3-position	No	120 s	1000 N	N4561
<b>SKD32.21</b>				Yes	30 s		
<b>SKD32.51</b>				No	120 s		
<b>SKD82.50</b>		AC 24 V		Yes	120 s		
<b>SKD82.51</b>				No	30 s		
<b>SKD60</b>				DC 0...10 V <sup>1)</sup>	No		
<b>SKD62...</b>				Yes	Yes		
<b>SKB32.50</b>	Electro-hydraulic	AC 230 V	3-position	No	120 s	2800 N	N4564
<b>SKB32.51</b>				Yes			
<b>SKB82.50</b>				No			
<b>SKB82.51</b>		Yes					
<b>SKB60</b>		DC 0...10 V <sup>1)</sup>		No			
<b>SKB62...</b>		Yes		Yes			
<b>SKC32.60</b>	Electro-hydraulic	AC 230 V	3-position	No	120 s	2800 N	N4564
<b>SKC32.61</b>				Yes			
<b>SKC82.60</b>				No			
<b>SKC82.61</b>		Yes					
<b>SKC60</b>		DC 0...10 V <sup>1)</sup>		No			
<b>SKC62...</b>		Yes		Yes			

<sup>1)</sup> or DC 4...20 mA

## Pneumatic actuators

Pneumatic actuators are available on request from your local office.

## Technical design / mechanical design

### Valve cross section

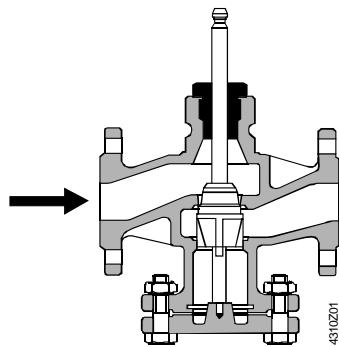

DN 15... 40  
closes against pressure

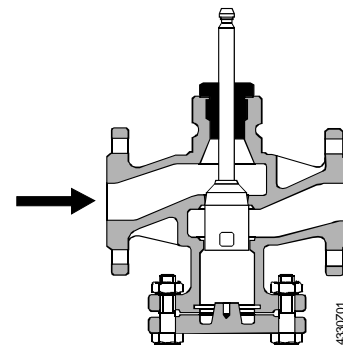

DN 50...150  
closes against pressure

Guided plug which is integrated in the valve stem.  
The seat is machined in the valve body.



**The two-port seat valve does not become a three-port valve by removing the blank flange!**

# Sizing

## Flow diagram

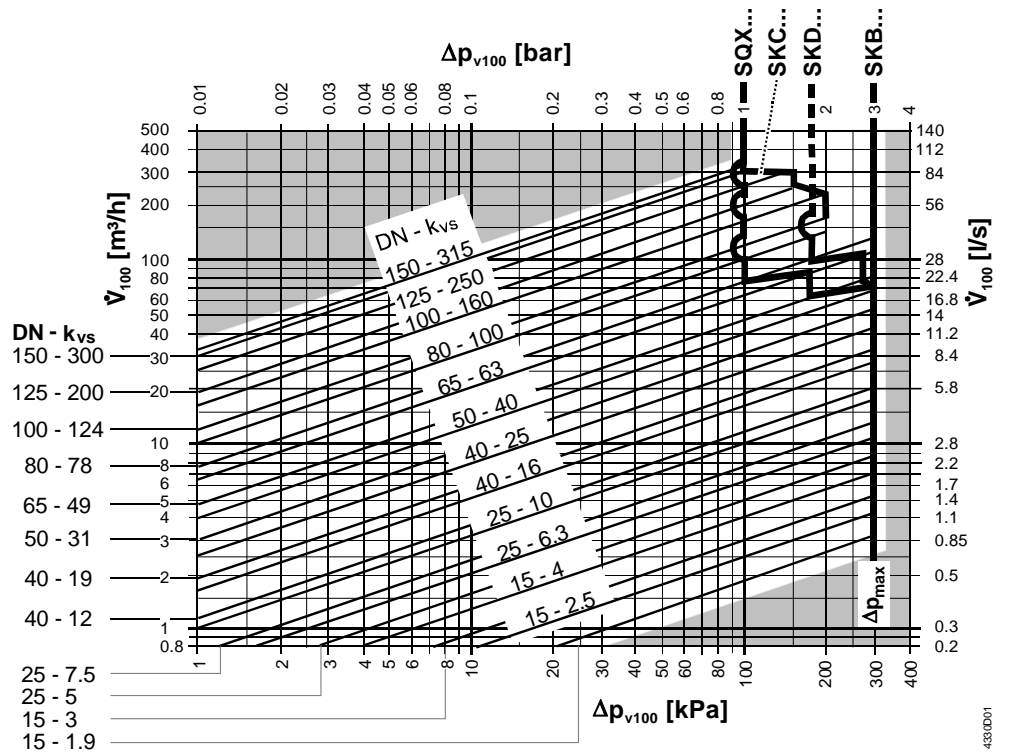

$\Delta p_{max}$  = Maximum permissible differential pressure across the valve's control path, valid for the entire actuating range of the motorised valve

$\Delta p_{v100}$  = Differential pressure across the fully open valve by a volume flow  $V_{100}$

$\dot{V}_{100}$  = Volume flow through the fully open valve ( $H_{100}$ )

100 kPa = 1 bar  $\approx$  10 mWC

1 m³/h = 0.278 l/s water at 20 °C

## Valve flow characteristic

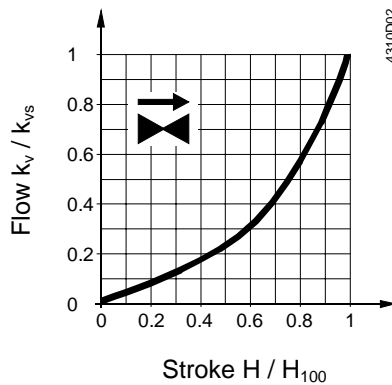

0...30 %  $\rightarrow$  linear

30...100 %  $\rightarrow$  equal percentage

$n_{gl} = 3$  as per VDI / VDE 2173

$k_{vs}$ -values 100, 160, 250, 315 m³/h:

0...30 %  $\rightarrow$  linear

30...75 %  $\rightarrow$  equal-percentage ( $n_{gl} = 3$ )  
as per VDI / VDE 2173

5...100 %  $\rightarrow$  optimized for maximal flow  
 $k_{v100}$

**Cavitation**

Cavitation accelerates wear on the valve plug and seat, and also results in undesirable noise. Cavitation can be avoided by not exceeding the differential pressure shown in the flow diagram on page 5, and by adhering to the static pressures shown below.

**Note on chilled water**

To avoid cavitation in chilled water circuits ensure sufficient counter pressure at valve outlet, e.g. by a throttling valve after the heat exchanger. Select the pressure drop across the valve at maximum according to the 80 °C curve in the flow diagram below.

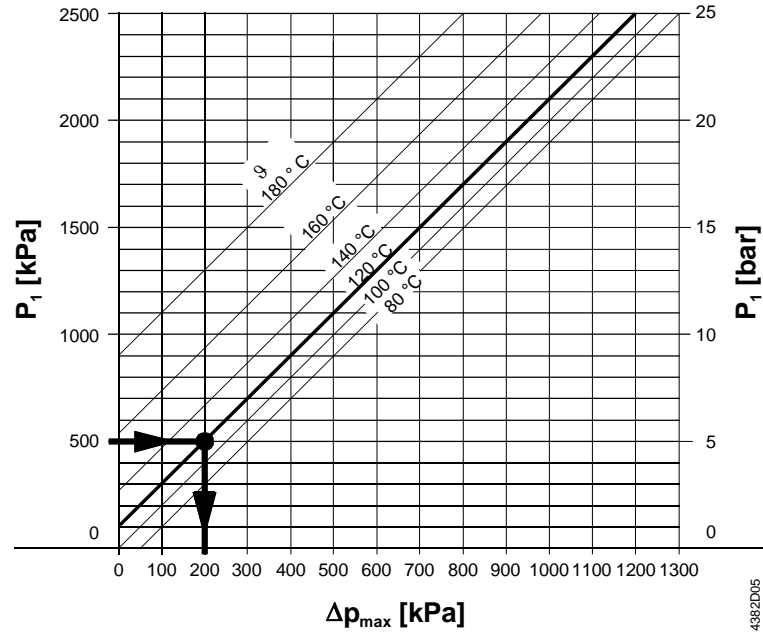

- $\Delta p_{max}$  = Differential pressure with valve almost closed, at which cavitation can largely be avoided
- $p_1$  = Static pressure at inlet
- $p_3$  = Static pressure at outlet
- M = Pump
- $\vartheta$  = Water temperature

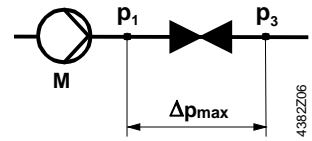

**High temperature hot water example:**

Pressure  $p_1$  at valve inlet: 500 kPa (5 bar)  
 Water temperature: 120 °C

From the diagram above, it will be seen that with the valve almost closed, the maximum permissible differential pressure  $\Delta p_{max}$  is 200 kPa (2 bar).

## Working pressure and medium temperature

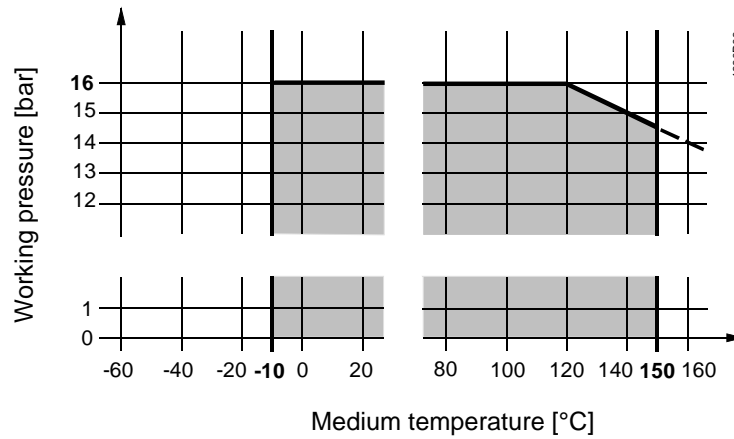

## Working pressure and medium temperature staged as per ISO 7005

Current local legislation must be observed.

## Notes

### Engineering

We recommend installation in the return pipe, as the temperatures in this pipe are lower for applications in heating systems, which in turn, extends the stem sealing gland's life.



Always use a strainer upstream of the valve to increase the valve's functional safety.



For media below 0 °C, use the electric ASZ6.5 stem heating element to prevent the valve stem from freezing in the sealing gland. For safety reasons, the stem heating element has been designed for AC 24 V / 30 W operating voltage.

### Mounting

Both valve and actuator can easily be assembled at the mounting location. Neither special tools nor adjustments are required.

The valve is supplied with Mounting Instructions 74 319 0509 0.

### Orientation

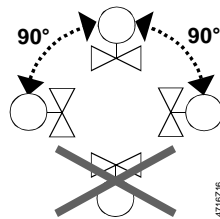

### Direction of flow

When mounting, pay attention to the valve's flow direction symbol →.

### Commissioning



**Commission the valve only if the actuator has been mounted correctly.**

Valve stem retracts: valve opens = increasing flow

Valve stem extends: valve closes = decreasing flow

## Maintenance

VVF40... valves require no maintenance.

### Warning

When doing service work on the valve / actuator:

- Deactivate the pump and turn off the power supply
- Close the shutoff valves
- Fully reduce the pressure in the piping system and allow pipes to completely cool down

If necessary, disconnect the electrical wires.

Before putting the valve into operation again, make certain the actuator is correctly fitted.

## Stem sealing gland

The glands can be exchanged without removing the valve, provided the pipes are depressurized and cooled off and the stem surface is unharmed.  
If the stem is damaged in the gland range, replace the entire stem-plug-unit.  
Contact your local office or branch.

## Disposal



Before disposal the valve must be dismantled and separated into its various constituent materials.

Legislation may demand special handling of certain components, or it may be sensible from an ecological point of view.

**Current local legislation must be observed.**

## Warranty

The technical data given for these applications is valid only in conjunction with the Siemens actuators as detailed under «Equipment combinations».

All terms of the warranty will be invalidated by the use of actuators from other manufacturers.

## Technical data

Functional data	PN class	PN 16 to ISO 7268	
	Working pressure	to ISO 7005 within the permissible medium temperature range according to the diagram on page 7	
	Flow characteristic	<ul style="list-style-type: none"><li>• 0...30 %</li><li>• 30...100 %</li><li>• linear</li><li>• equal percentage; <math>n_{gl} = 3</math> to VDI / VDE 2173 <sup>1)</sup></li></ul>	
	Leakage rate	0...0.02 % of $k_{vs}$ value to DIN EN 1349	
	Permissible media	chilled water, low temperature hot water, high temperature hot water, water with anti-freeze, brine; recommendation: water treatment to VDI 2035	
	Medium temperature <sup>2)</sup>	-10...+150 °C	
	Rangeability $S_v$	DN 15...40: >50 DN 50...150: >100	
	Nominal stroke	DN 15...80: 20 mm DN 100...150: 40 mm	
	Industry standards	Pressure Equipment Directive	PED 97/23/EC
		Pressure Accessories	as per article 1, section 2.1.4
Fluid group 2:		<ul style="list-style-type: none"><li>• DN 15...50</li><li>• DN 65...125</li><li>• DN 150</li><li>• without CE-marking as per article 3, section 3 (sound engineering practice)</li><li>• category I, with CE-marking</li><li>• category II, with CE-marking, test authority number 0036</li></ul>	
Materials	Valve body	grey cast iron EN-GJL-250	
	Stem	stainless steel	
	Plug	DN 15...40: brass DN 50...150: bronze	
	Sealing gland	Brass, siliconfree	
	Gland materials	EPDM O rings, siliconfree	
Dimensions / Weight	Refer to «Dimensions»		
	Flange connections	to ISO 7005	

<sup>1)</sup>  $k_{vs}$ -values 100, 160, 250, 315 m<sup>3</sup>/h: flow characteristic is over 75 % stroke optimized for maximal flow  $k_{v100}$ , see page 5.

<sup>2)</sup> Electric stem heating element ASZ6.5 required for media below 0 °C.



## Dimensions

Dimensions in mm

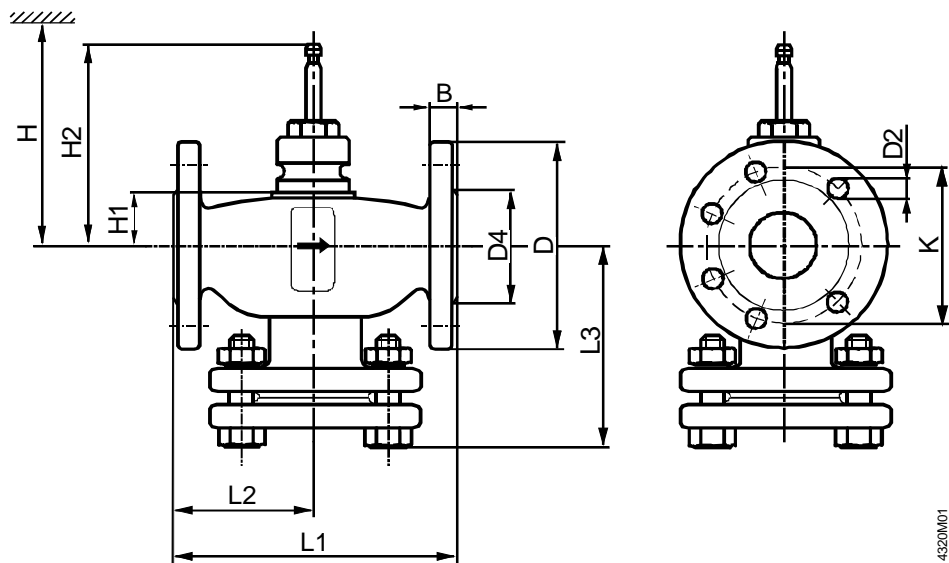

Valve	DN	B	D Ø	D2 Ø	D4 Ø	K	L1	L2	L3	H1	H2	H				[kg]
												SQX...	SKD...	SKB...	SKC...	
VVF40.15-1.9	15	14	95	14 (4x)	46	65	130	65	86	40,5	137	> 465	> 540	> 615		4,1
VVF40.15-2.5																4,1
VVF40.15-3																4,1
VVF40.15-4																4,1
VVF40.25-5	25	16	115	19 (4x)	65	85	160	80	104	34	130,5	> 459	> 534	> 609		6,3
VVF40.25-6.3																6,3
VVF40.25-7.5																6,3
VVF40.25-10																6,3
VVF40.40-12	40	18	150	19 (4x)	84	110	200	100	126	39	135,5	> 464	> 539	> 614		10,4
VVF40.40-16																10,4
VVF40.40-19																10,4
VVF40.40-25																10,4
VVF40.50-31	50	20	165	19 (4x)	99	125	230	115	143	60	156,5	> 485	> 560	> 635		13,8
VVF40.50-40																13,8
VVF40.65-49	65	20	185	19 (4x)	118	145	290	145	173	60	156,5	> 485	> 560	> 635		18,5
VVF40.65-63																18,5
VVF40.80-78	80	22	200	19 (4x)	132	160	310	155	185	93	209,5	> 485	> 560	> 635		24,1
VVF40.80-100																24,1
VVF40.100-124	100	24	220	19 (8x)	156	180	350	175	205	104	220,5	> 485	> 560	> 635		> 666
VVF40.100-160																> 666
VVF40.125-200	125	26	250	23 (8x)	184	210	400	200	232	120	236,5	> 485	> 560	> 635		> 677
VVF40.125-250																> 677
VVF40.150-300	150	26	285	23 (8x)	211	240	480	240	275	120	236,5	> 485	> 560	> 635		> 693
VVF40.150-315																> 693

DN = Nominal size

H = Total actuator height plus minimum distance to the wall or the ceiling for mounting, connection, operation, maintenance etc.

H1 = Dimension from the pipe centre to install the actuator (upper edge)

H2 = Valve in the «Closed» position means that the stem is fully extended

## Order numbers for spare parts

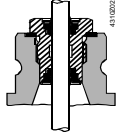
Valve	Sealing gland 	Set  Plug with stem, circlip, sealing
VVF40.15-1.9	4 284 8806 0	74 676 0140 0
VVF40.15-2.5	4 284 8806 0	74 676 0198 0
VVF40.15-3	4 284 8806 0	74 676 0141 0
VVF40.15-4	4 284 8806 0	74 676 0199 0
VVF40.25-5	4 284 8806 0	74 676 0034 0
VVF40.25-6.3	4 284 8806 0	74 676 0200 0
VVF40.25-7.5	4 284 8806 0	74 676 0035 0
VVF40.25-10	4 284 8806 0	74 676 0201 0
VVF40.40-12	4 284 8806 0	74 676 0036 0
VVF40.40-16	4 284 8806 0	74 676 0202 0
VVF40.40-19	4 284 8806 0	74 676 0037 0
VVF40.40-25	4 284 8806 0	74 676 0203 0
VVF40.50-31	4 284 8806 0	74 676 0038 0
VVF40.50-40	4 284 8806 0	74 676 0204 0
VVF40.65-49	4 284 8806 0	74 676 0039 0
VVF40.65-63	4 284 8806 0	74 676 0205 0
VVF40.80-78	4 284 8806 0	74 676 0040 0
VVF40.80-100	4 284 8806 0	74 676 0206 0
VVF40.100-124	4 679 5629 0	74 676 0088 0
VVF40.100-160	4 679 5629 0	74 676 0207 0
VVF40.125-200	4 679 5629 0	74 676 0089 0
VVF40.125-250	4 679 5629 0	74 676 0208 0
VVF40.150-300	4 679 5629 0	74 676 0090 0
VVF40.150-315	4 679 5629 0	74 676 0090 0